

PAPER • OPEN ACCESS

Design of a Fuzzy Controller for a Hybrid Generation System

To cite this article: J. R. Nuñez *et al* 2020 *IOP Conf. Ser.: Mater. Sci. Eng.* **844** 012017

View the [article online](#) for updates and enhancements.

You may also like

- [A device inspired by the mantis shrimp's strike to produce cavitation bubbles on solid surfaces](#)

F A Godínez, J E V Guzmán, R Valdés et al.

- [Hands-On Physics with Homemade Tetra Pak Sensors: building capacitors and testing their functionality](#)

Marcos Mazini, Sofia Favre, Carla Yelpe et al.

- [Deposition of Multilayer Films of ZnO by Sol-gel Process on Stainless Steel Substrates for Energy Harvesting Devices](#)

L A Uscanga-González, E A Elvira-Hernández, R Pérez-Cuapio et al.



The Electrochemical Society
Advancing solid state & electrochemical science & technology



249th
ECS Meeting
May 24-28, 2026
Seattle, WA, US
Washington State
Convention Center

Spotlight Your Science

**Submission deadline:
December 5, 2025**

SUBMIT YOUR ABSTRACT

Design of a Fuzzy Controller for a Hybrid Generation System

J. R. Nuñez^{1*}, J. Mestre², J. J. Cabello³, H. Dominguez⁴, J. Fong⁵, L. Peña⁶, I. Benítez⁷, D. De Oliveira⁸

^{1,3}Departamento de Energía, Facultad de Ingeniería, Universidad de la Costa, Calle 58 No 55-66, 080002, Barranquilla, Colombia.

^{2,5,7}Departamento de Automática, Facultad Ingeniería Eléctrica, Universidad de Oriente, Ave Las Américas, s/n, 90300, Santiago de Cuba, Cuba.

⁴Departamento de Informática, Facultad Ingeniería Informática, Telecomunicaciones y Biomédica, Universidad de Oriente, Ave Las Américas, s/n, 90300, Santiago de Cuba, Cuba.

⁶Departamento de Desarrollo, UEB Santiago de Cuba, Empresa de Hidroenergía, Ave Las Américas, s/n, 90300, Santiago de Cuba, Cuba.

⁸Departamento de Electricidad, Campus Reitor Joao David Ferrer Lima s/n. 88040-970. Universidad Federal de Santa Catarina, Florianópolis. Brasil.

* jnunez22@cuc.edu.co

Abstract. This paper presents the design of a control system for the automatic connection/disconnection and distribution of load, between an asynchronous alternator and a generator, in a hydroelectric central that works in isolated mode. The design of a control algorithm based on fuzzy logic is exposed, as this is a flexible method to be used in different installations with a variety of technology. The controller is supported on the Arduino Mega 2560 platform, in order to develop a low-cost system with its own technology, it is tested by computer simulation using the professional software Proteus v7.7, which guarantees that once validated the correct operation of the controller can be migrated to another system, say for example a PLC. The results obtained are shown and the simulations performed to the different blocks of the system are explained.

1. Introduction

Factors such as climate change and the increase in energy demand make a change in global energy policy increasingly urgent [1, 2]. The exploitation of Renewable Sources of Energy (RSE) is the main alternative for this change, since they are clean energies by not emitting CO₂ and can be applied both in networks interconnected to electrical systems and in isolated areas [3, 4, 5, 6].

The application of RSE in isolated areas has as main drawback its instability, which makes it necessary to use hybrid systems that guarantee permanent power supply [4, 6]. The operation of hybrid power generation systems in isolated areas of the National Electric System (NES) has as one of its main challenges to ensure the parameters of energy quality and permanent supply regardless of the climatic conditions and the RSE that can replace [7, 8].

In this work the design of an automatic control system for the hybrid generation system integration is made, to be used in an isolated area of the NES, using a hydraulic installation and a Diesel Generator Set (DGS), supported on the platform Arduino Mega 2560. Using artificial intelligence techniques, the operation of the system is simulated to guarantee the electrical supply in an isolated community,



verifying the correct functioning of the algorithm developed based on fuzzy logic for the connection and disconnection of the generating sources, as well as the correct synchronization between these sources [9, 10]. Developing this work, the design and validation of a low-cost controller that is part of an electrical generation system using hydraulic energy in mountainous areas of the eastern region of Cuba, which are totally isolated from the National Electro Energetic System (SEN), is obtained.

2. Methodology

The implementation of the controller is developed through the XP software development methodology adapted, which consists of the following phases: Planning, Design, Coding and Testing.

2.1. System proposal

During the work development, the following parameters were considered: frequency, power and the phase shift between the two generating sources. Both have voltage control and the micro hydroelectric plant also has a frequency controller [11, 12]. The generation system that is proposed to automate is composed of:

- A Small Hydroelectric Plant (SHP) with a synchronous generator, and an asynchronous motor which is used as a generator. For the asynchronous motor, a speed control is required, which consists in varying the opening of the water inlet to the turbine that puts it in motion, in order to bring the motor to synchronism with the synchronous generator and then generate up to 30% of the nominal power of the synchronous generator to help generate power when necessary.
- A DGS with frequency automatically regulated to the frequency of the PCH.

For the measurement of frequency and electrical power, standardized output transducers from 0 to 5 V and 0 to 10 V are used, respectively, which allow the controller to make the measurements and make decisions about the generating sources (DGS, SHP or both) to satisfy the energy demand, as well as that of establishing an order of priority for the connection and disconnection of these sources in case the resource of all is needed. Other parameters controlled are the phase shift, the water inlet valve to the turbine of the PCH and the frequency of the GE. The controller used is the Arduino Mega 2560 because it is economical and has the required capabilities. At this stage of the work, and due to the complexity involved in the design of the controller, the study focuses only on the control signals that the Arduino receives and sends to carry out the whole process of connecting and disconnecting the generating sources, by what the electrical machines involved in the process are analyzed as a black box. It is expected that in future research work the dynamic behavior of each of them will be studied. Figure 1 shows a block diagram of the different parts of the system to be automated.

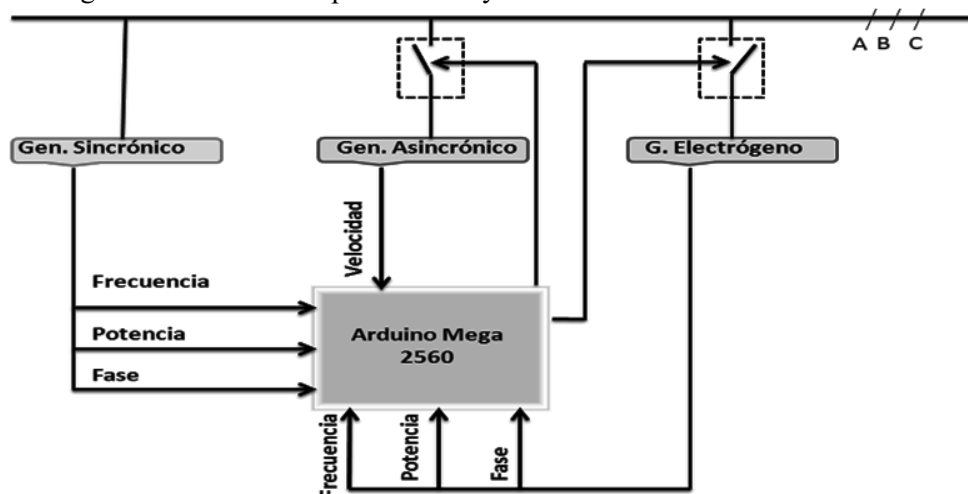

Figure 1. System Blocks Diagram. Source: The authors

2.2. Functional requirements

For the design of the controller, two modes of operation, manual and automatic, are defined, with the following requirements:

- Manual Mode:
 - RF1- Show the variables measured and controlled (Power and frequency of the SHP and DGS, asynchronous generator speed of the SHP and phase angle);
 - RF2- Control asynchronous generator;
 - RF2.1- Power on / off asynchronous generator;
 - RF2.2- Connect asynchronous generator to the network.
 - RF3- Control the power of the SHP through the water inlet valve;
 - RF3.1- Turn in positive direction the three-phase reversible motor for opening the valve;
 - RF3.2- Turn in a negative direction the three-phase reversible motor for closing the valve.
 - RF4- Control the DGS;
 - RF4.1- Power on / off the DGS;
 - RF4.2- Connect DGS to the network;
 - RF4.3- Sort increase / decrease the speed of the DGS generator.
 - RF5- Calculate phase angle.
- Automatic Mode:
 - RF6- Select mode according to the availability of sources and demand;
 - RF6.1- Operate only with the SHP and the asynchronous generator;
 - RF6.2- Operate only with SHP and the DGS;
 - RF6.3- Operate with the SHP, the asynchronous generator and the DGS.
 - RF7- Indicate flow level;
 - RF8- Activate alarm produced by low flow;
 - RF8.1- Eliminate alarm caused by low flow.
 - RF9- Provide some degree of intelligence to the controller, so that he can make correct decisions about auxiliary sources when operating in automatic mode.

2.3. Fuzzy Logic

Fuzzy control consists of establishing a series of rules to control actions that allow combining input variables, and by means of a relation of rules they result in one or more output values [13]. To satisfy the RF9, the designed controller is equipped with a certain degree of intelligence through fuzzy logic and a set of fuzzy rules so that it can make decisions when working in automatic mode and execute them with its switching system. For this, the fuzzy logic library (eFLL) for Arduino was used [14]. This library makes use of the Maximum and Minimum algorithms and Mamdani for inference and composition as well as the Area Center for defuzzification in a continuous universe [3].

Making use of this library defines the input set of the electric power values with the linguistic terms (low, medium, high), which are created using the FuzzySet function (w, x, y, z). The system is constantly measuring the power of the network, which is blurred through the function fuzzify(), and, according to the degree of belonging that has the value read power, to one of the defined linguistic terms, it is taken the decision to connect or disconnect the asynchronous generator and / or the DGS. For example: if the measured power has a degree of belonging greater than the term "high" than the term "average", then, according to the availability of the asynchronous generator and the DGS, and according to the water level, the decision is made to connect each one or both to help in the generation. Therefore, when the degree of belonging is greater than the term "average" or "low" that at the end "high", then the decision is taken to disconnect one or both auxiliary sources that are connected [15, 16].

The fuzzy set of power input was created through an object of the FuzzyInput class called power, this object contains three objects of the FuzzySet class called low1, medium1 and high1, leaving the set defined as shown in figure 2.

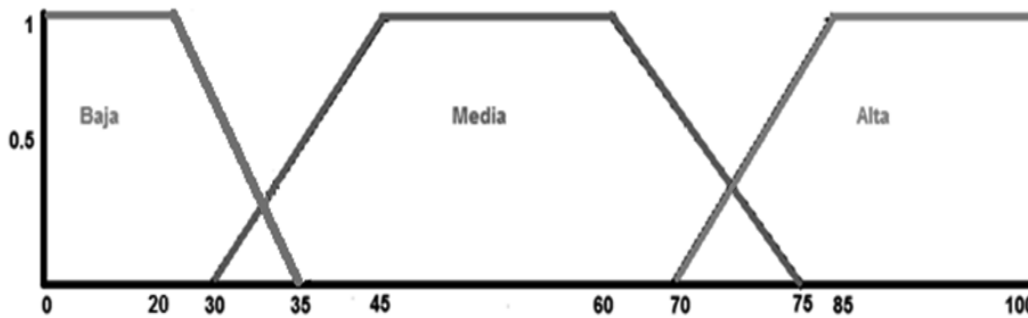

Figure 2. Input membership function (Power). Source: The authors.

To obtain the behavior of the different variables, a trapezoidal function model is established that represents each set of system variables denoted by ranges within the universe of discourse.

$$\mu_{\text{trapezoidal}}(x, a, b, c, d) = \begin{cases} 0; & x < a \\ \frac{x-a}{b-a}; & a \leq x \leq b \\ 1; & b \leq x \leq c \\ \frac{d-x}{d-c}; & c \leq x \leq d \\ 0; & d \leq x \end{cases} \quad (1)$$

Equation for the low diffuse set:

$$\mu_{\text{low}}(x, 0, 0, 20, 35) = \begin{cases} 1; & 0 \leq x \leq 20 \\ \frac{1}{25}(-x + 35); & 20 < x < 35 \\ 0; & 35 \leq x \end{cases} \quad (2)$$

Equation for the average diffuse set:

$$\mu_{\text{average}}(x, 30, 45, 60, 75) = \begin{cases} 0; & x < 30 \\ \frac{1}{15}(x - 30); & 30 \leq x < 45 \\ 1; & 45 \leq x \leq 60 \\ \frac{1}{15}(-x + 75); & 60 < x \leq 75 \\ 0; & 75 < x \end{cases} \quad (3)$$

Equation for the high diffuse set:

$$\mu_{\text{high}}(x, 70, 85, 100, 100) = \begin{cases} 0; & x < 70 \\ \frac{1}{15}(x - 70); & 70 \leq x < 85 \\ 1; & x \leq 85 \end{cases} \quad (4)$$

From the above equations it is obtained that, e.g., for a power value (read from the power transducer) equivalent to 73% after performing the blurring of this value through the functions fuzzy→ setInput (1, pot) and fuzzy → fuzzify(), belonging to the eFLL library. It reaches a degree of belonging to the diffuse set average = 0.13 and a degree of belonging to the diffuse set high = 0.2. Therefore, as the power begins to be "high" because the degree of belonging to the "average" group is less than the degree of belonging to the "high" group, then the asynchronous generator or the DGS is put into operation depending on the

availability and water level, and subsequently connects the generator to the grid to help with cogeneration.

This behavior is obtained from the set of fuzzy rules defined for the controller:

- If power is high, flow is enough, asynchronous motor is available and asynchronous motor is off, then ignite asynchronous motor;
- If power is high, DGS is available and off, then turn on generator set;
- If power is high, asynchronous motor is available and off, has enough flow, generator set is available and generator set is off, then turn on asynchronous motor [17];
- If power is high, asynchronous motor is available, motor is off, flow is insufficient and DGS is available and off, then turn on DGS;
- If power is high, asynchronous motor is available, has enough flow rate, asynchronous motor is on and DGS is available and off, then turn on DGS;
- If power is medium or low and asynchronous motor is on, then shut off asynchronous motor;
- If power is medium or low and DGS is on, then turn off the DGS;
- If power is medium or low, asynchronous motor is on and DGS is off, then shut off asynchronous motor;
- If power is medium or low, asynchronous motor is on and DGS is on, then turn off DGS.

The use of this controller makes the installation of the PCH system more flexible with different hydraulic and technological characteristics because it is based on fuzzy logic for decision making, which makes it possible to simplify the system since it is not necessary to know the mathematical model of the plant, unlike, for example, PID controllers. In addition, the use of the Arduino as a controller is an economically feasible option to acquire, develop and implement.

2.4. Controller's work sequence

In the controller programming and considering that always it should be the SHP who defines the voltage and frequency parameters of the network, two modes of work are required, the manual and the automatic. In addition, the controller follows a strategy of cyclical planning in which it supervises that all the tasks that are executed within the main cycle comply with the times defined for each one. At the same time, for the work in automatic mode, the diffuse rules described above are defined, which allow a normal operation regime, and which depends on the following conditions:

2.4.1. Condition 1: Abundant flow and only the asynchronous generator available as auxiliary source

Connection process: The controller is measures and always blurs the power of the SHP. When this reaches a value belonging to the fuzzy set "high", the system sends a signal to start the asynchronous generator which starts to open the water inlet valve until the synchronous speed is reached. Then it connects with the SHP, it waits for a time of approximately 2 seconds and it takes it up to 30% of the generation power of the SHP, thus achieving cogeneration. Figure 3 shows the behavior that the controller follows in this condition.

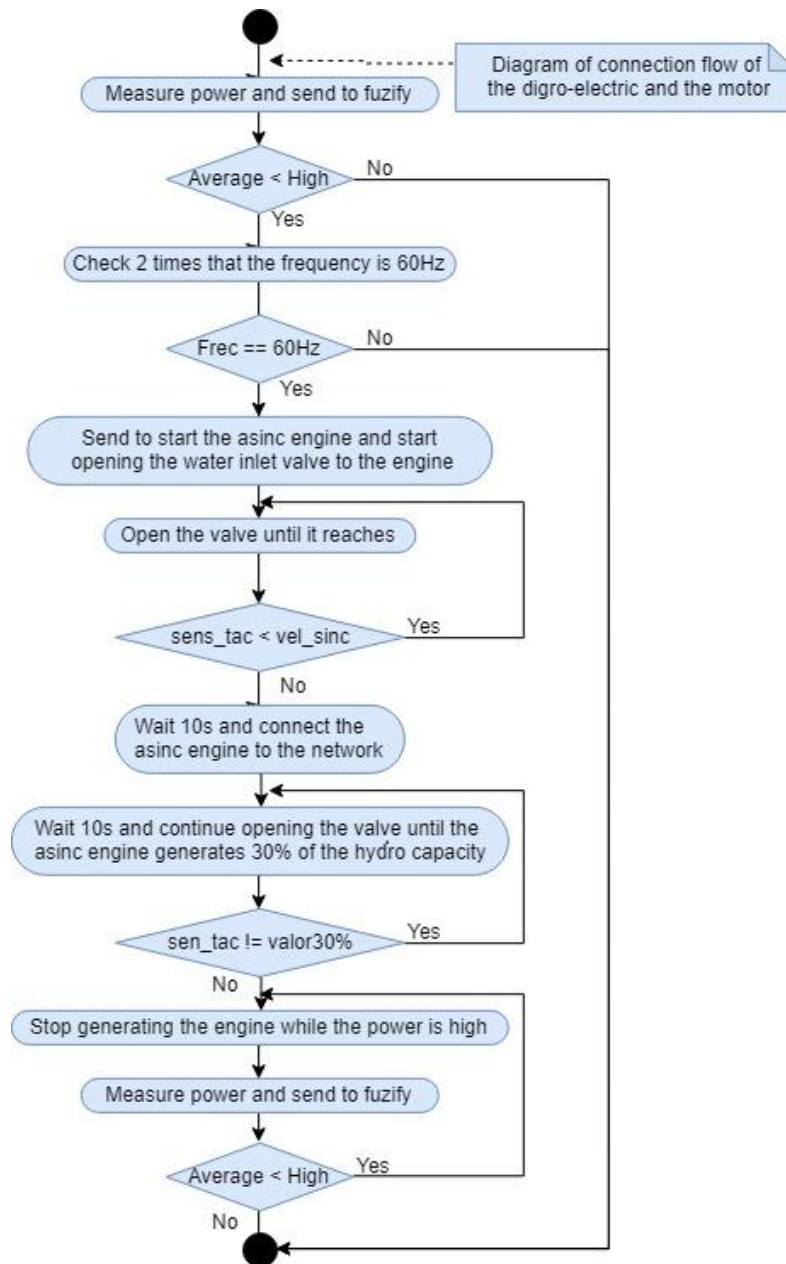

Figure 3. Flow diagram of the connection sub-process of the micro hydroelectric plant and the asynchronous generator. Source: The authors.

Disconnection process: The controller permanently measures and blots the power of the SHP. When it reaches a value of belonging to the fuzzy set "average" greater than a value of belonging to the fuzzy set "high", or a value greater than zero of the set fuzzy "low", begins to close the water inlet valve to the turbine of the asynchronous generator and waits for a certain time, until it reaches the synchronous speed. Then, disconnects it from the SHP and continues closing the valve until the speed of the asynchronous generator is less than 5% of the maximum value. Figure 4 shows this behavior.

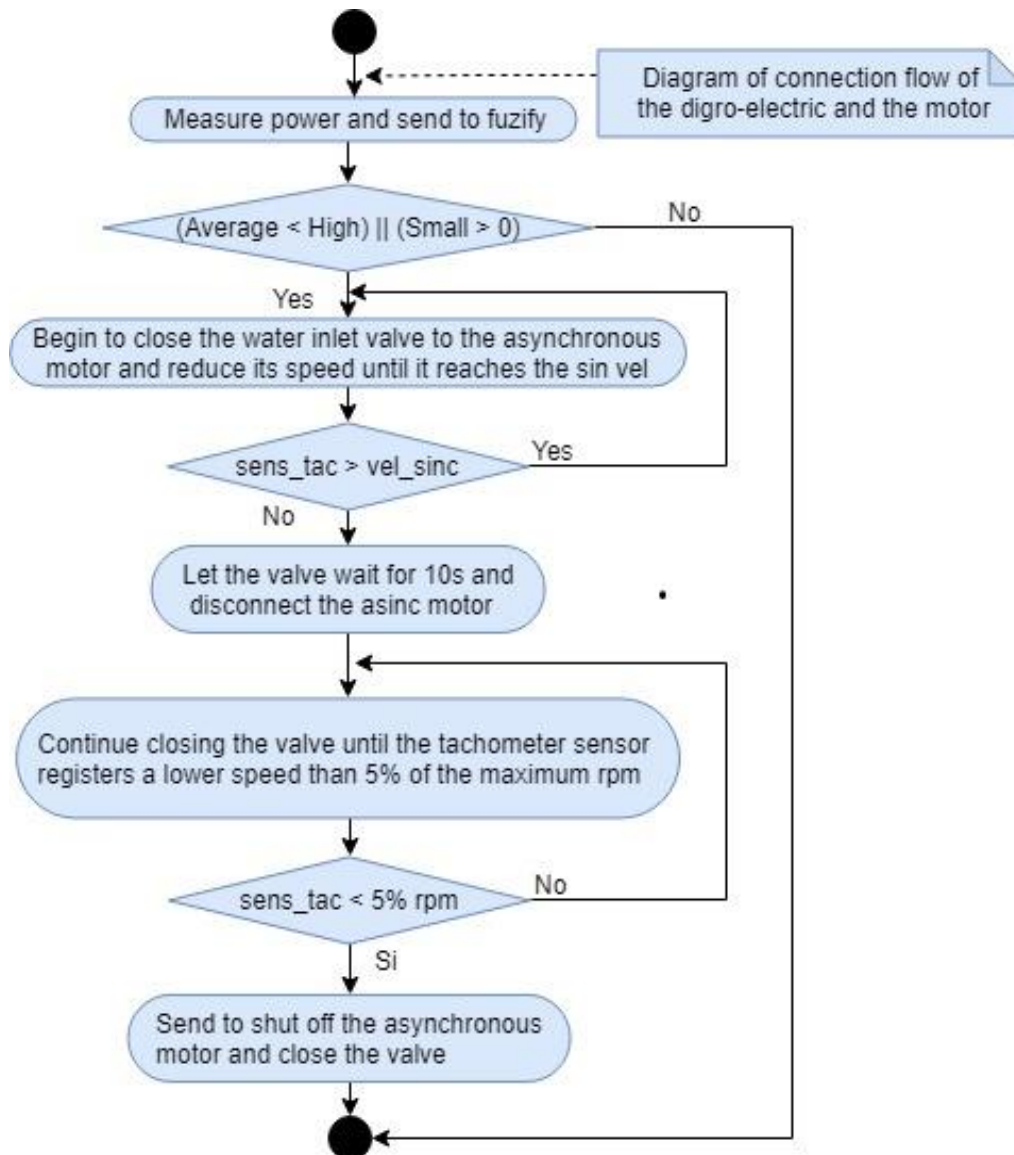

Figure 4. Flow diagram of the disconnection sub-process of the micro hydroelectric plant and the asynchronous generator. Source: The authors.

2.4.2. Condition 2: Only the generator set (DGS) available as an auxiliary source

Connection process: the controller permanently measures and blots the power of the SHP (PotCH). When it reaches a value of belonging to the fuzzy set "high", greater than a value of belonging to the set fuzzy "average", then the system turns on the DGS, verifies that its frequency is equal to that of the SHP in a range of ± 0.2 Hz according to [18]. If they are not equal, the system increases or decreases the speed of the DGS to adjust its frequency. If they are equal, it is verified that the phase shift is less than 15° , and if it is fulfilled, the DGS is connected in vacuum with the SHP, 10 seconds are expected and the generation power of the DGS is increased up to 100% of its capacity. The flow chart of Figure 5 shows the behavior of the controller in this case.

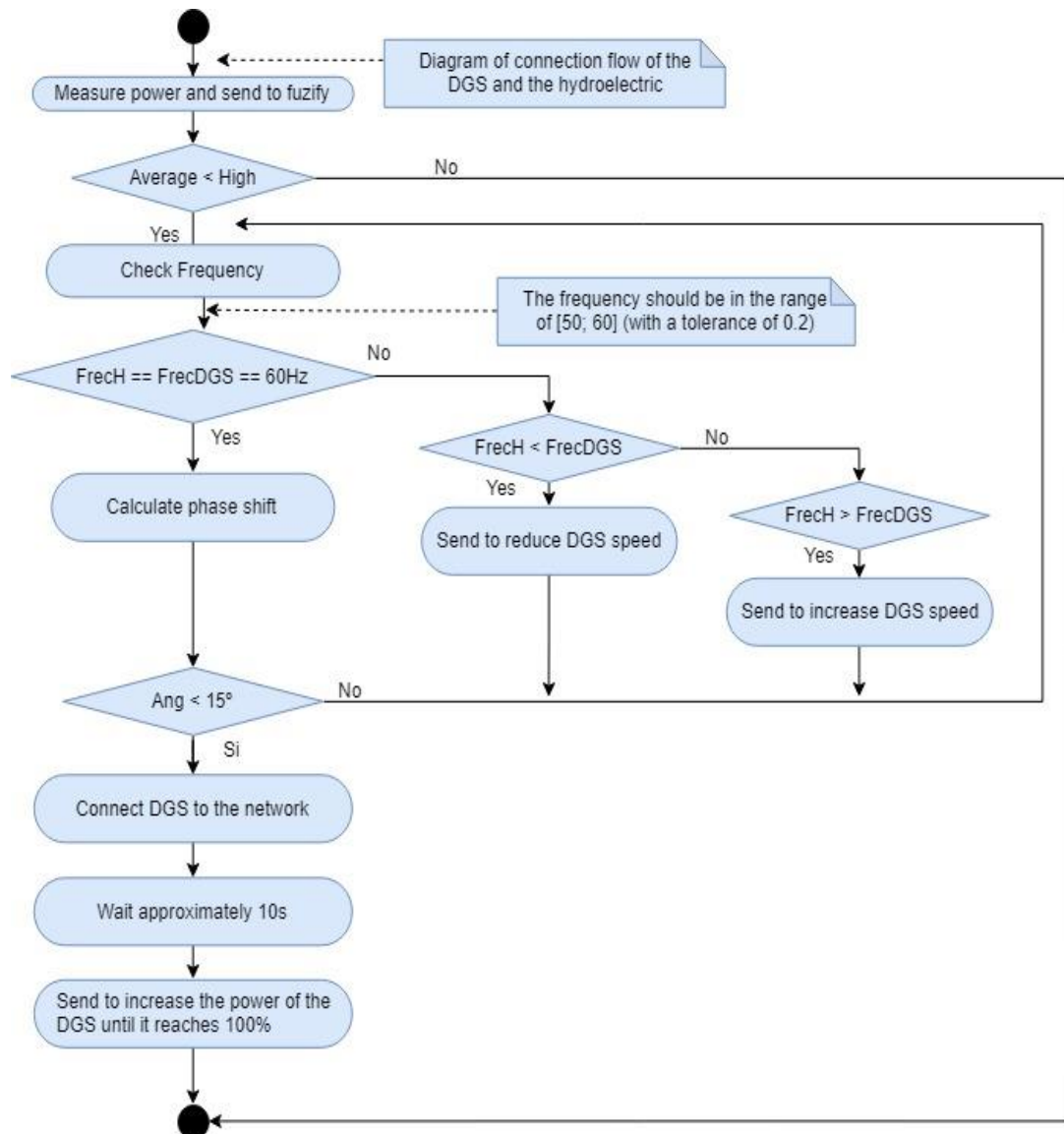

Figure 5. Flow diagram of the connection sub-process of the micro hydroelectric plant and the DGS. Source: The authors.

Disconnection process: the controller permanently measures and smudges the power of the SHP (PotCH). When it reaches a value belonging to the fuzzy set "average" greater than a value of belonging to the fuzzy set "high" or a value greater than zero of the fuzzy set "low", the system decreases the power of the DGS to 0%, waits for 10 seconds disconnects it from the SHP and turns off the DGS (See figure 6).

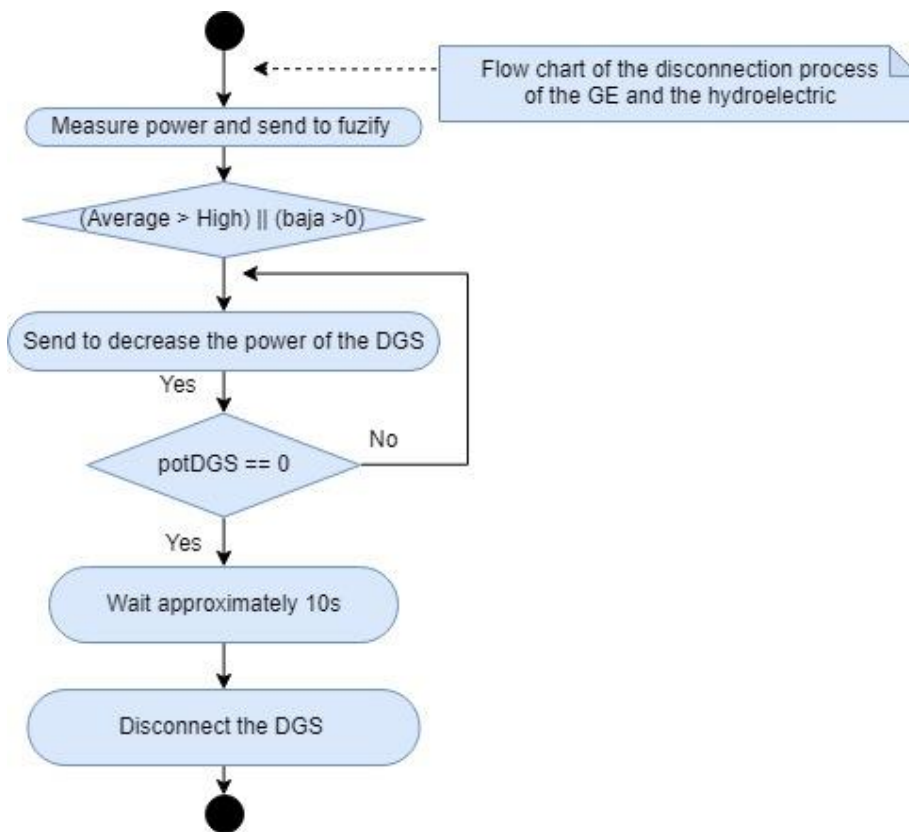

Figure 6. Flow diagram of the disconnection sub-process of the micro hydroelectric plant and the DGS. Source: The authors.

2.4.3. Condition 3: Abundant flow and asynchronous generator and DGS available as auxiliary sources

Connection process: the controller measures and permanently blots the power of the SHP (PotCH). When it reaches a value belonging to the fuzzy set "high" greater than a value of belonging to the fuzzy set "average". The system starts the asynchronous generator and begins to open the water inlet valve to the turbine of the asynchronous generator until it reaches the synchronous speed and then connects it with the SHP, waits 2 seconds and takes it up to 30% of the SHP generation power, remaining these cogenerating. Wait 10 seconds. If the power continues to be high, the DGS is connected and it is verified that the DGS frequency is equal to that of the SHP in ± 0.2 Hz according to [18]. If they are not equal, the system commands to increase or decrease the speed of the DGS to adjust this frequency. If they are equal, it is verified that the phase shift is less than 15° and the DGS is switched on with the SHP, 10 seconds are expected and the power of the DGS is increased to its nominal capacity, thus leaving the asynchronous generator and the DGS cogenerating with the SHP.

Disconnection process: the controller measures and blots always the power of the SHP (PotCH). When it reaches a value belonging to the fuzzy set "average" greater than that of the fuzzy set "high" or a value greater than zero of the set fuzzy "low", the system decreases the power of the DGS to 0%, waits 10 seconds, disconnects it from the SHP and turns off the DGS. Wait 10 seconds. If the power continues to be low, then the system reduces the opening of the water inlet valve to the turbine of the asynchronous generator until it reaches the synchronous speed and disconnects it from the micro SHP and continues closing the valve until the speed of the asynchronous generator is less than 5% of the maximum, leaving only the SHP working.

In manual mode, the operator has a panel through which he can make decisions about the two auxiliary sources.

If it operates on the asynchronous generator through several actuators, it can:

- Turn on / off the asynchronous generator.
- Control the water inlet valve to the turbine, to vary the speed of the asynchronous generator and bring it to synchronous speed and 30% of the generation power of the SHP.
- Connect / disconnect the asynchronous generator in parallel with the hydroelectric power plant.

In the case of the DGS:

- Turn on / off the DGS.
- Measure the phase shift between the HPH and the DGS.
- Increase / decrease the power of the DGS.
- Connect / disconnect in parallel the DGS with the SHP.

3. Results and Discussion

In the coding stage several programmed functions were defined in C language that satisfy all the established functional requirements. Among the main functions can be mentioned:

- void Fuzificar_Potencia: This function receives as a parameter a value of type double, which is equivalent to the power value read from the power transducer and performs the blurring of this value to start making decisions from it.
- void connect_Sinc_Asin: This function receives as parameter an integer value that reflects the state (synchronized / non-synchronized) of the asynchronous generator. (See figure 3).
- void disconnect_Sinc_Async: This function receives as parameters two variables of type bool that allow knowing if the asynchronous generator is on and connected to the network, or if it is only on, as well as the third parameter an integer value is passed, which allows making decisions jointly with the function connect_Sinc_Async, this variable allows to divert the flow of the program from one point to another. (See figure 4).
- void conecta_Hidro: is responsible for connecting the synchronous generator and the DGS. (See figure 5).
- void disconnect_Hidro_GE (): it oversees disconnecting the synchronous generator and the DGS. (see figure 6).

To carry out the simulation tests of all the functions performed by the controller, the PROTEUS 7.7 professional program is used, which provides the possibility of simulating them in real time and, in addition, programming the Arduino Mega 2560 and representing the tasks it performs.

The system (see figure 7) is composed of the Arduino Mega 2560, an alphanumeric LCD LM044L of 20x4, potentiometers to simulate the output signal of the transducers and the tachometer, 8 LEDs to indicate the status of the relays and the status indicators both asynchronous generator and the DGS. It also has 4 logicprobe to indicate the status of the control relays for closing / closing the water inlet valve to the turbine of the asynchronous generator and to indicate the increase or decrease in the speed of the DGS generator. It also has a switch to clear the alarm if it occurs and 14 logicstate to manually control the different parameters, both the asynchronous generator and the DGS, and to select manual / automatic mode, simulate the flow level and the availability of different sources.

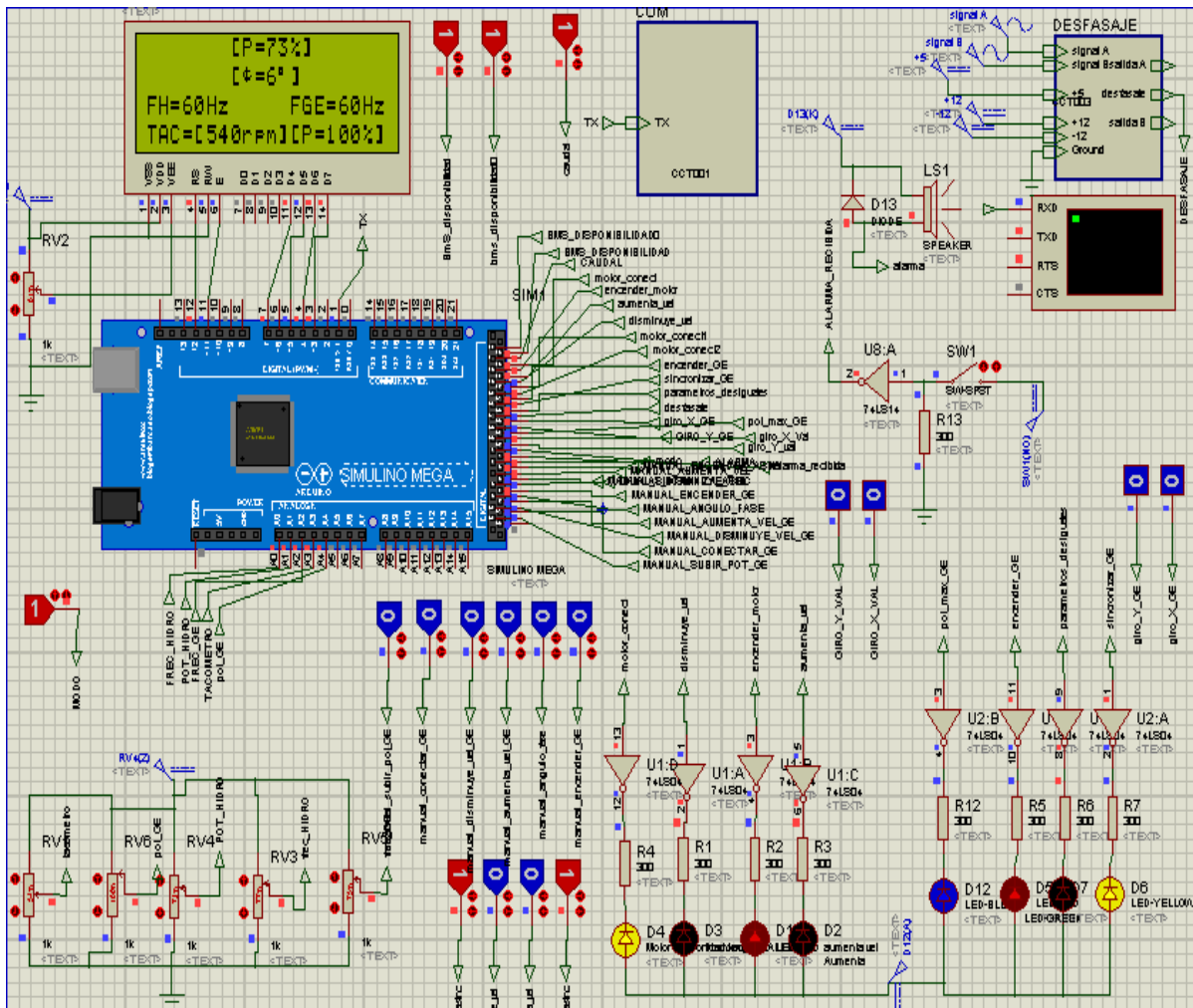

Figure 7. Simulation of the system in Proteus. Source: The authors.

3.1. Simulation of the transducers and the tachometric sensor and visualization of the controlled variables

The simulation of the frequency and power measurements of the DGS and SHP transducers are made with potentiometers, as is the simulation of the tachometric sensor measurement of the asynchronous generator speed. The voltage outputs of these are connected to 5 analogue inputs of the Arduino Mega 2560 (A0- frequency of the SHP, A1- power of the SHP, A2- frequency of the DGS, A3- tachometric sensor and A4- power of the GE).

Measurements of the variables: SHP frequency (FH), DGS frequency (FGE), power (P) of the SHP and DGS power, phase shift (ϕ) and speed (TAC) are displayed on a 20x4 LM044L LCD.

3.2. Work simulation with the asynchronous generator

For the work with the asynchronous generator, the on/off simulation is simulated, using a red LED connected to pin 26 of the Arduino. To simulate the connection in parallel with the SHP, a yellow LED connected to pin 25 is used. To indicate the increase/decrease of the speed of the motor, two LEDs are used, one green connected to the pin 27 which indicates if it is necessary to increase the speed and a blue LED connected on the pin 28 which indicates that it is necessary to decrease the speed of the generator, to bring the asynchronous generator to the synchronous speed and to increase or decrease the power generated by it. These two indicators work in conjunction with 2 logicprobe connected to pins

38 and 39, these logic probes are used to simulate the relays that control the opening and closing of the water inlet valve to the turbine of the asynchronous generator.

Figure 8 shows the simulation test of the work with the asynchronous generator. The red LED indicates that the asynchronous generator is on, the yellow LED indicates that the generator is connected to the network. The green LED indicates that the speed of the asynchronous generator must be increased to take it to 30% of the generation power of the micro hydroelectric plant and the logic probe with the combination -01- indicate the activation of the relay, which allows the opening of the valve of water input to the turbine to increase the power of the asynchronous generator.

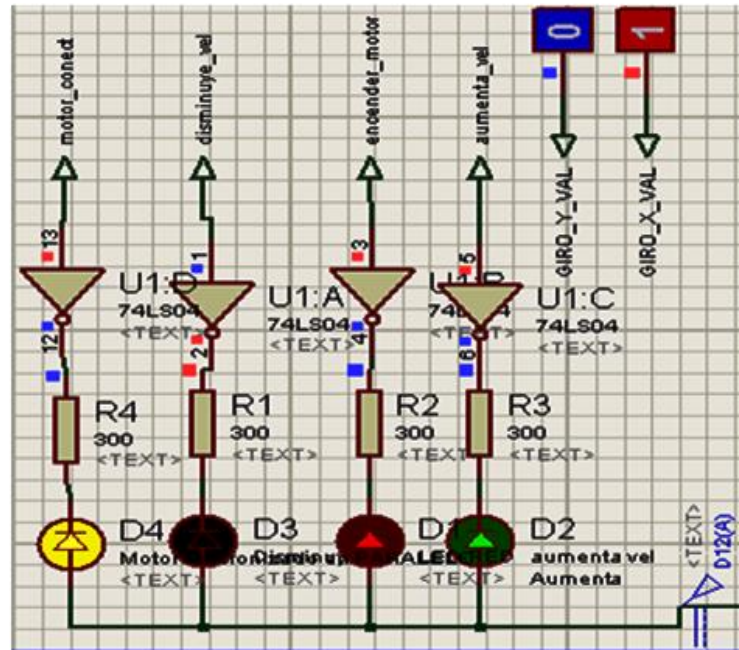

Figure 8. State of the indicators and relays that control the asynchronous motor. Source: The authors.

3.3. Connection of the auxiliary relays with the arduino for the parallel connection of the asynchronous generator with the synchronous generator

For the connection of the asynchronous generator with the synchronous generator, the use of power relays is necessary. The modules admit high intensity peaks, and consequently, have enough reserves to activate the connected fuses. They also resist capacitive and inductive interferences without problems.

3.4. Connection of relays for three-phase reversible motor drive

Figure 9 shows the connection diagram used in the drive control of the three-phase reversible motor that regulates the valve that controls the flow of water entering the turbine that moves the asynchronous generator.

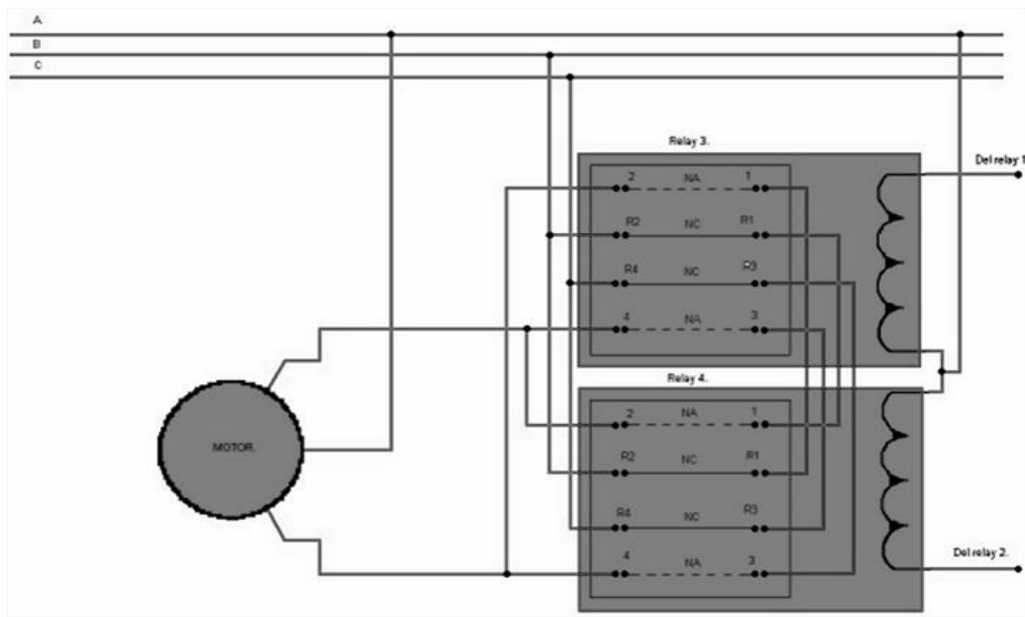

Figure 9. Connection diagram of the relays for control of rotation of the three-phase reversible motor.
Source: The authors.

The operating principle of the motor drive is as follows:

The Arduino has two digital outputs (pins 38 and 39) responsible for connecting the relay system to control the rotation of the three-phase reversible motor.

To achieve a correct performance of the motor operation, two relays, model MULTI9, were selected as final stage, which have four contacts, two normally open and two normally closed. Its connection is shown in figure 9, where it is observed that the motor drive is only carried out if one of the relays is activated and the other is not, that is, if one of the coils is energized and the other is not. In case the coils of relays three and four, respectively, are energized or de-energized, the motor remains at rest. For the motor to rotate one way or the other, only one of the coils, relay coil three or relay coil four must be energized, so that the normally open contacts close, and the normally closed contacts open, allowing the start and start-up of the engine.

To activate relays three and four (see figure 9), the drive coils are connected to lines B and C of the network, and through two micro relays (see figure 10), relays three and four are activated. These micro relays are activated by the control signal coming from the Arduino (pins 38 and 39), according to the state (code) programmed according to the following rule:

- Code 00: Micro relays one and two are deactivated, therefore relays three and four are in normal state. Three-phase motor at rest.
- Code 11: Activated micro relays one and two, therefore in activated state relays three and four. In this state the normally open contacts close, and the normally closed contacts open. Three-phase motor at rest.
- Code 01: Micro relay one is activated, therefore the coil of relay three is energized and relay four is kept deactivated, therefore the normally closed contacts of relay three are opened and the normally open contacts are closed. In this condition the three-phase motor is energized and rotates in one direction.
- Code 10: The micro relay two is activated, therefore the coil of relay four is energized and relay three is kept deactivated, therefore the normally closed contacts of relay four are opened and the normally open contacts are closed. In this condition, the three-phase motor is energized and rotated in the opposite direction.

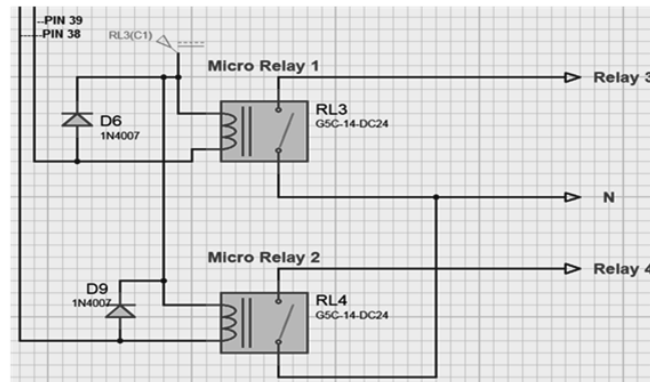

Figure 10. Connection diagram of micro relays 1 and 2. Source: The authors.

3.5. *Simulation of work with the DGS*

For the work with the DGS, the on / off simulation is simulated using a red LED connected to pin 31 of the Arduino; To simulate the connection in parallel with the SHP, a yellow LED connected to pin 32 is used. To indicate the inequality between the parameters of frequency and phase angle measured from the SHP and DGS, a green LED connected to pin 33 is used, when being on reflects the inequality between these parameters. Furthermore, when the blue led connected to pin 37 is on it indicates that the DGS is generating at its maximum power, and the 2 logicsprobe indicate the increase or decrease of the DGS speed to increase its power generation.

Figure 11 shows the simulation performed of the DGS operation. The red led indicates that the DGS is on, the green LED off indicates that the frequencies measured in the central micro and the DGS coincide and that these are between 60 ± 0.2 Hz and that in addition the measured phase shift between the DGS and the micro central does not exceed 15° as recommended [18]. The yellow LED indicates that the DGS is connected to the network. The logicsprobe with the combination -01- indicate the increase of the speed to bring the DGS to its maximum power generation and as this is not yet at the maximum of its power, then the blue LED remains off, because this it only turns on when the DGS is generating at maximum power.

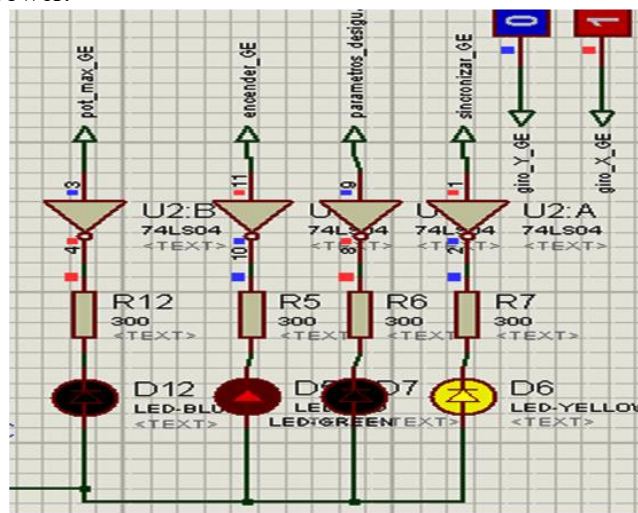

Figure 11. State of the indicators and relays that control the generator set. Source: The authors.

3.6. *Calculation of the phase angle*

For the phase measurement, two sinusoidal signals, whose phase shift between them is to be measured, are converted into rectangular pulses. The separation between the pulses of the signals is equal to the phase shift between them. In figure 12 two sinusoidal waves are shown offset by an angle Δt .

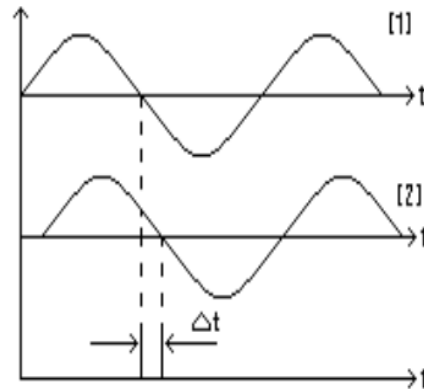

Figure 12. Graph of two signals offset in time. Source: [19].

The phase can be expressed as:

$$\varphi = \omega \Delta t \tag{5}$$

Where ω is the angular velocity, in rad-sec, and Δt is the time, in seconds, between the zero crossing of signals 1 and 2.

$$\Delta t = \frac{\varphi}{\omega} \tag{6}$$

The time difference Δt is directly proportional to the phase shift φ and inversely proportional to the angular velocity ω , so that an electric circuit is formed that generates a rectangular pulse of duration Δt [20, 21]. The circuit shown in Figure 13 is used to convert sine waves into rectangular waves.

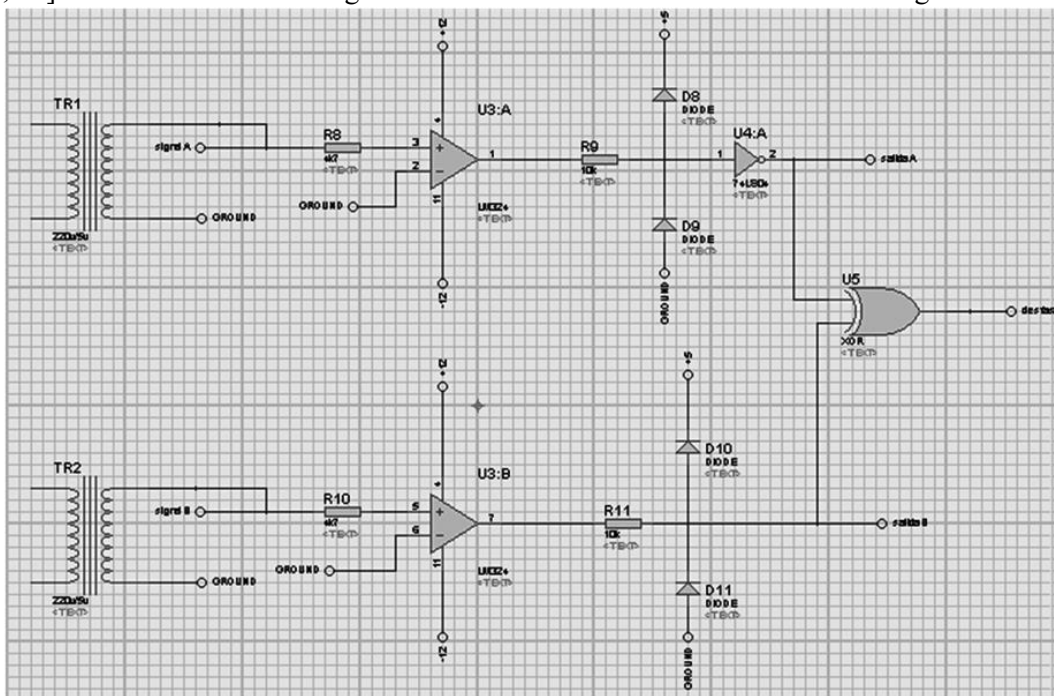

Figure 13. Circuit for phase measurement. Source: The authors.

Firstly, the voltage value of a phase of the micro hydroelectric plant and one phase of the DGS are transformed to voltage values of 5V by the transformers TR1 and TR2. Then, the signal is sent to the comparators that are formed by the operational amplifiers LM324, and in the comparators the sinusoidal waves are converted into rectangular waves. These square waves maintain the same phase shift as the sinusoidal waves.

The signal offset at a given angle is taken to a NOT gate, integrated circuit 7404, where it is inverted and then an exclusive sum is made by an XOR gate with the reference signal, at the gate exit a proportional rectangular pulse is obtained at the phase shift, see figure 14. This pulse is taken to the Arduino through pin 34 and is captured by the PulseIn function where the time of the impulse generated by the circuit is obtained and it is taken to the value of the phase shift.

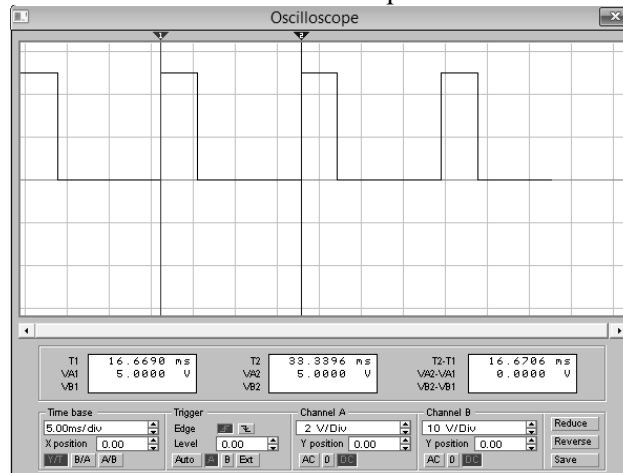

Figure 14. Circuit output signal for phase measurement. Source: The authors.

3.7. Work mode selection

The designed controller allows two modes of operation: manual and automatic. These modes can be selected through a connected logicstate on pin 42, a value of "0" written on this pin selects manual mode and a value of "1" written selects automatic mode.

For the operation in manual mode, there is a set of logicstate that allows the control of both the asynchronous generator and the DGS. For control of the asynchronous generator, there are four logicstates that allow the following operations:

- Turn the generator on/off (pin 43).
- Increase the generation power of the asynchronous generator and therefore the opening of the water inlet valve to the turbine (pin 44).
- Decrease the generating power of the asynchronous generator and therefore close the water inlet valve to the turbine (pin 45).
- A combination on the pins 44 and 45 of -01- indicates increasing the opening of the valve and a combination of -10- indicates decreasing the opening of the valve. A combination of -00- or -11- on these pins would leave the valve at rest, and a generator connected to pin 46 is used to connect the generator to the grid.

For control of the DGS there are five logicstates that allow the on / off (pin 47), calculate the phase shift (pin 48), increase / decrease the speed of the DGS to control its frequency or take it to the maximum / minimum of its power, pin generation 49 and 50, a combination of -01- on these pins indicates the increase in the generator speed of the DGS and a combination of -10- indicates the decrease in speed, any other combination would have no effect. To connect the DGS to the network, the logicstate connected to pin 51 is used.

Figure 15 shows the simulation of the operation in manual mode of the asynchronous generator and the DGS, in it the state of the indicators described above for the control of each of the auxiliary sources of power generation is reflected.

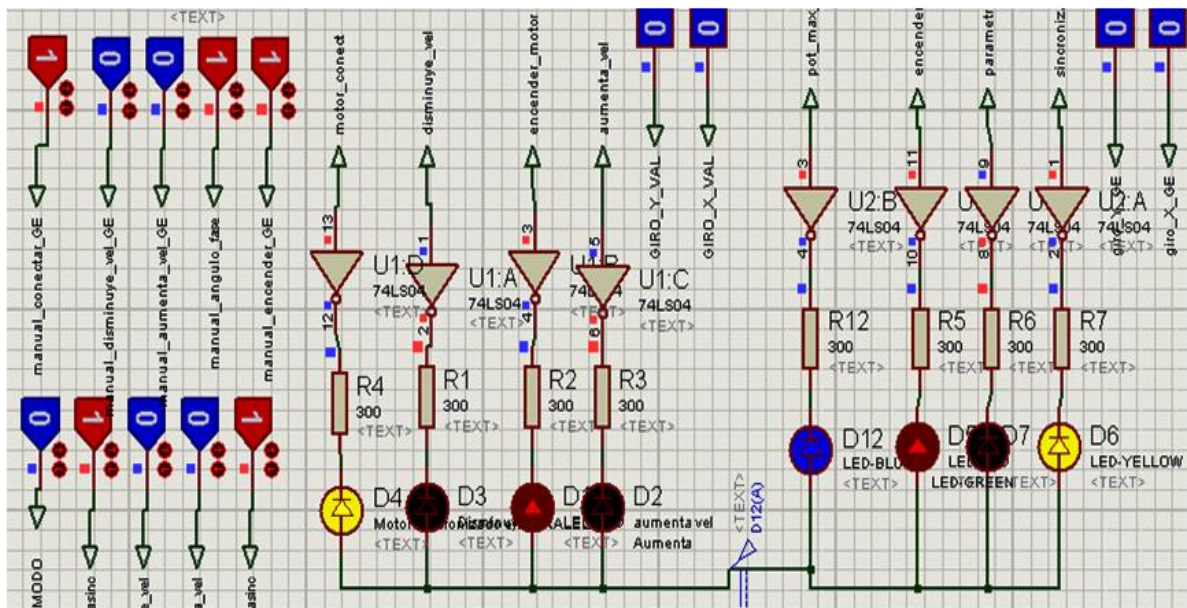

Figure 15. Operation in manual mode of the asynchronous generator and generator set.

Asynchronous generator on (red led on the left) and connected to the grid (yellow led on the left) and DGS on (red led on the right), connected to the grid (yellow led on the right) and generating at maximum power (blue led). Source: The authors.

For operation in automatic mode, there are three logicstates that are used to indicate the flow level (pin 24). A value of "0" written on this pin indicates insufficient flow, which makes the use of the asynchronous generator as an auxiliary source impossible of generation and a value of "1" written on this pin indicates that the flow is enough which allows the asynchronous generator to be used as an auxiliary generation source.

The logicstate connected to pins 22 and 23 are used to select the three working modes that the controller allows in automatic mode. These modes are derived from the auxiliary sources available to assist in the generation, so a combination of -00- pins indicates that neither the asynchronous generator nor the DGS are available to cogenerate with the SHP. A combination of -01- indicates that it can only cogenerate with the SHP the asynchronous generator; a combination of -10- indicates that only the DGS can cogenerate with the SHP, and a combination of -11- indicates that both the asynchronous generator and the DGS can be used as auxiliary sources for generation. Working in automatic mode, the controller makes use of all the rules defined using fuzzy logic for the decision making of the sources that are needed in the generation.

In the event that the operator selects the automatic mode and indicates that the flow is insufficient and selects a combination of -01- (on pins 22 and 23), it would select the asynchronous generator as an auxiliary source and because the reservoir flow rate it is not abundant, then an alarm is activated (pin 40) indicating to the operator that the asynchronous generator cannot be used because the flow is low.

4. Conclusion

In this work, the simulation of the operation of an electrical generation system is obtained using the hydraulic energy that guarantees the supply of energy to an isolated community of the National Electrical System, verifying the proper functioning of the algorithm developed based on the fuzzy logic for the connection and disconnection of the generating sources, as well as the correct synchronization between these sources.

An automatic control system is designed for a hybrid electric generation system that operates in an isolated operation regime, consisting of a hydroelectric central (SHP) with synchronous and

asynchronous alternators and a generator, taking advantage of the potential offered by the Arduino Mega platform 2560, which simplifies the hardware.

A control algorithm is selected that makes system installation flexible to SHP with different hydraulic and technological characteristics.

The tests are performed by simulation using Proteus 7.7, which shows the correct functioning of the design.

The design made allows the use of other controllers such as PLCs or PIC controllers.

References

- [1] Noa A and Montero R. 2017. Comportamiento operacional de grupos electrógenos: particularidades del índice de consumo específico de combustible. *Ingeniería Mecánica*. vol. 21. No. 1. pp. 19-27
- [2] Núñez Alvarez, José Ricardo et al. 2019. Metodología de diagnóstico de fallos para sistemas fotovoltaicos de conexión a red. *Revista Iberoamericana de Automática e Informática industrial*, [S.l.], sep. 2019. ISSN 1697-7920. Disponible en: <<https://polipapers.upv.es/index.php/RIAI/article/view/11449>>
- [3] Andújar J. M and Barragán A. J. 2014. Hibridación de sistemas borrosos para el modelado y control. *RIAI-Revista Iberoamericana de Automática e Informática Industrial*. vol. 11, núm. 2, pág. 127-141
- [4] Beleño K. J and Berrio J. S. 2013. Diseño de una smart grid para un sistema híbrido de energía. *Prospect*. vol. 11, No. 2, págs. 94-101
- [5] Guerrero J. W, Toscano A, Pacheco L. V, Tovar J. O. 2018. Analysis of the Energetic and Productive Effects Derived by the Installation of a Conveyor Belt in the Metal-mechanic Industry. *International Journal of Energy Economics and Policy*. 8(6), 196-201. DOI: 10.32479/ijeeep.7066
- [6] Valencia G, Nuñez, J and Acevedo C. 2019. Research Evolution on Renewable Energies Resources from 2007 to 2017: A Comparative Study on Solar, Geothermal, Wind and Biomass Energy. *International Journal of Energy Economics and Policy*. 9(6), 242-253. DOI: <https://doi.org/10.32479/ijeeep.8051>
- [7] Colectivo de autores. 2017. Cogeneración de energía, eléctrica y térmica, mediante un sistema híbrido biomasa-solar para explotaciones agropecuarias en la isla de Cuba. *Editorial CIEMAT*, Madrid, España
- [8] Fong J, Domínguez H, Benítez I and Nuñez J. R. 2018. Smart Grid proposal in communities of Guama Municipality of Santiago de Cuba Province. *Journal of Engineering and Technology for Industrial Applications*. 2018. Vol. 04. Nº 13, pp 61-69
- [9] Real Calvo, Rafael et al. 2017. Sistema Electrónico Inteligente para el Control de la Interconexión entre Equipamiento de Generación Distribuida y la Red Eléctrica. *Revista Iberoamericana de Automática e Informática industrial*. v 14, n. 1, p. 56-69. ISSN 1697-7920
- [10] Marín J. D. 2103. Estudio del Control de una Pequeña Central Hidroeléctrica para la Operación por Micro Redes en el Sistema de Distribución Local. *Facultad de Ingeniería y Arquitectura*. Universidad Nacional de Colombia. Manizales. Colombia
- [11] Barrero F, Milanés M. I, González E, Roncero C and González P. 2015. El Control de Frecuencia y Potencia en los Sistemas Eléctricos Multitarea. Revisión y Nuevos Retos. *Revista Iberoamericana de Automática e Informática Industrial*. vol. 12, núm. 4, pág. 355-500. DOI: 10.1016/j.riai.2015.07.001
- [12] Salazar A and Fong J 2004. Mediciones Eléctricas. Empresa Editorial Poligráfica Félix Varela. Edición 2004-06-06. ISBN 978-959-258-758-8
- [13] Asprilla D. B. 2016. Estudio de Sistemas Híbridos de Energía Renovable (solar – gasificación de biomasa) como alternativa para satisfacer necesidades energéticas en Zonas no Interconectadas del Departamento del Chocó. Tesis de maestría para optar al grado de Máster en Ingeniería Mecánica. Facultad de Minas. Universidad Nacional de Colombia. Medellín, Colombia
- [14] eFLL - A Fuzzy Library for Arduino and Embeded Systems. Disponible en <https://blog.zerokol.com/2012/09/arduinofuzzy-fuzzy-library-for-arduino.html>

- [15] Espino A. 2017. Control de Temperatura con lógica difusa para un sistema de espectroscopia láser. Trabajo de diploma en opción a título de Ingeniero Electrónico. Facultad de Ingeniería. Universidad Nacional Autónoma de México
- [16] Barragán A. J, Al-Hadithi B. M, Andújar J. M and Jiménez A. 2015. Metodología formal de análisis del comportamiento dinámico de sistemas no lineales mediante lógica borrosa. *Revista Iberoamericana de Automática e Informática Industrial RIAI*. 12 (4), 434–445
- [17] Valencia G, Nuñez J and Duarte J. 2019. Multiobjective Optimization of a Plate Heat Exchanger in a Waste Heat Recovery Organic Rankine Cycle System for Natural Gas Engines. *Entropy*. 21(7), 655
- [18] Rodríguez S and Sarmiento A. 2015. Competitividad de los sistemas híbridos eólicos-fotovoltaicos para la electrificación rural. *Ingeniería Mecánica*. vol.18 no.1. ISSN on-line 1815-5944
- [19] Mikati M, Santos M and Armenta C 2012. Modelado y Simulación de un Sistema Conjunto de Energía Solar y Eólica para Analizar su Dependencia de la Red Eléctrica. *Revista Iberoamericana de Automática e Informática Industrial-RIAI*. vol. 9, núm. 3. pp. 267-281
- [20] Bordons C, García F and Valverde L. 2015. Gestión Óptima de la Energía en Microrredes con Generación Renovable. *Revista Iberoamericana de Automática e Informática industrial*, [S.l.] vol. 12, n. 2, p. 117-132
- [21] Guerrero J. W, Toscano A, Pacheco L. V and Tovar J. 2018. Analysis of the Energetic and Productive Effects Derived by the Installation of a Conveyor Belt in the Metal-mechanic Industry. *International Journal of Energy Economics and Policy*. 8(6), 196-201