

C. elegans EGL-9 and Mammalian Homologs Define a Family of Dioxygenases that Regulate HIF by Prolyl Hydroxylation

Andrew C.R. Epstein,¹ Jonathan M. Gleadle,¹
Luke A. McNeill,² Kirsty S. Hewitson,²
John O'Rourke,¹ David R. Mole,¹ Mridul Mukherji,²
Eric Metzen,¹ Michael I. Wilson,¹ Anu Dhandu,²
Ya-Min Tian,¹ Norma Masson,¹
Donald L. Hamilton,¹ Panu Jaakkola,¹
Robert Barstead,³ Jonathan Hodgkin,⁴
Patrick H. Maxwell,^{1,6} Christopher W. Pugh,^{1,6}
Christopher J. Schofield,^{2,6} and Peter J. Ratcliffe^{1,5,6}

¹The Henry Wellcome Building of Genomic Medicine
Roosevelt Drive
Oxford OX3 7BN
United Kingdom

²The Oxford Centre for Molecular Sciences
and The Dyson Perrins Laboratory
South Parks Road
Oxford OX1 3QY
United Kingdom

³Oklahoma Medical Research Foundation
825 NE 13th Street
Oklahoma City, Oklahoma 73104

⁴Genetics Unit
Department of Biochemistry
South Parks Road
Oxford OX1 3QU
United Kingdom

Summary

HIF is a transcriptional complex that plays a central role in mammalian oxygen homeostasis. Recent studies have defined posttranslational modification by prolyl hydroxylation as a key regulatory event that targets HIF- α subunits for proteasomal destruction via the von Hippel-Lindau ubiquitylation complex. Here, we define a conserved HIF-VHL-prolyl hydroxylase pathway in *C. elegans*, and use a genetic approach to identify EGL-9 as a dioxygenase that regulates HIF by prolyl hydroxylation. In mammalian cells, we show that the HIF-prolyl hydroxylases are represented by a series of isoforms bearing a conserved 2-histidine-1-carboxylate iron coordination motif at the catalytic site. Direct modulation of recombinant enzyme activity by graded hypoxia, iron chelation, and cobaltous ions mirrors the characteristics of HIF induction in vivo, fulfilling requirements for these enzymes being oxygen sensors that regulate HIF.

Introduction

Oxygen homeostasis presents a fundamental physiological challenge that requires the coordinate regulation of extensive arrays of genes. In mammalian cells, the transcriptional complex hypoxia inducible factor (HIF) has emerged as a key regulator of these processes,

playing a central role in both local and systemic responses to hypoxia (Semenza, 2000b; Wenger, 2000). In keeping with this, HIF is activated in a broad array of ischemic/hypoxic and neoplastic diseases (Semenza, 2000a). The central role of HIF in developmental, physiological, and pathophysiological responses to hypoxia has therefore provided a focus for efforts to understand the underlying mechanisms of oxygen sensing and signal transduction.

HIF binds to a core DNA sequence A/(G)CGTG within hypoxia response elements as a heterodimer of basic helix-loop-helix PAS proteins designated HIF- α and HIF- β subunits (Wang et al., 1995). HIF- α subunits are specific to the response to hypoxia whereas HIF- β subunits are constitutive nuclear proteins that also participate in other transcriptional responses. Both proteins exist as isoforms, and at least two mammalian HIF- α isoforms, HIF-1 α and HIF-2 α , are regulated by oxygen in a similar manner (Semenza, 2000b; Wenger, 2000).

In normoxia, HIF- α subunits are rapidly destroyed by the ubiquitin-proteasome pathway such that steady-state levels are low and the transcription complex cannot form (Huang et al., 1998; Salceda and Caro, 1997; Sutter et al., 2000). In hypoxia, this process is suppressed and levels increase rapidly. Though regulated proteolysis therefore provides the dominant control mechanism, other processes provide additional points of regulation in a multistep activation process (Semenza, 2000b; Wenger, 2000). Activation of the HIF system by iron chelators and cobaltous ions as well as hypoxia has led to the proposal of a ferroprotein oxygen sensor, though the nature of such a protein(s) and mode(s) of interaction with HIF have remained largely unclear (Semenza, 1999; Zhu and Bunn, 2001).

Recently, new insights into the mechanism of regulation by availability of oxygen have been gained from studies of the role of the von Hippel-Lindau tumor suppressor protein (VHL) in proteolytic degradation. Both HIF-1 α and HIF-2 α contain an extensive transferable oxygen-dependent degradation domain (ODDD) (Huang et al., 1998; O'Rourke et al., 1999). VHL interacts with subsequences within the HIF- α ODDDs, acting as the recognition component of a multiprotein ubiquitin E3 ligase complex (Cockman et al., 2000; Kamura et al., 2000; Maxwell et al., 1999; Ohh et al., 2000; Tanimoto et al., 2000). Further analysis of this interaction has shown that the recognition of HIF- α subunits by VHL is regulated through enzymatic hydroxylation of specific prolyl residues within the HIF- α ODDD (Ivan et al., 2001; Jaakkola et al., 2001; Masson et al., 2001). Though the enzyme was not identified in these studies, indirect analysis of substrate requirements and inhibition by 2-oxoglutarate analogs suggested that the HIF-prolyl hydroxylase(s) (HIF-PHs) are likely to belong to the extended superfamily of 2-oxoglutarate-dependent-oxygenases (for review, see Hegg and Que, 1997; Schofield and Zhang, 1999). Since enzymes of this type have an absolute requirement for dioxygen as cosubstrate, these predictions provided a direct link between the regulation

⁵Correspondence: peter.ratcliffe@imm.ox.ac.uk

⁶These authors contributed equally to this work.

of HIF and molecular oxygen, and suggested a role for the postulated enzyme(s) as oxygen sensors.

To pursue these potential insights into oxygen sensing and proteolytic targeting by prolyl hydroxylation, we aimed to identify and characterize the relevant enzyme(s) using a combination of evolutionary, genetic, and biochemical methods. In this work, we demonstrate the existence of an HIF- α homolog (HIF-1) in *C. elegans* that is identical to that identified in recently published independent work describing mutant worms lacking this gene (Jiang et al., 2001). We further show that regulation of this homolog is dependent on a conserved mechanism of targeting by a VHL homolog following prolyl hydroxylation. Analysis of mutant worms identified the *egl-9* gene as critical for this process, and we show that the product is a 2-oxoglutarate-dependent dioxygenase that regulates HIF-1 through prolyl hydroxylation at a conserved core LXXLAP motif, thus defining a novel class of prolyl hydroxylase. In mammalian cells, we show that this family is represented by a series of isoforms that act differentially on prolyl hydroxylation sites within HIF- α , and that recombinant enzyme activity is directly modulated by oxygen tension, providing the basis for an oxygen sensing function.

Results

Identification and Characterization of a HIF- α Homolog in *C. elegans*

We first sought homologs to HIF- α subunits in the *C. elegans* EST database using a tBLASTn enquiry with the human sequence. The EST contig we identified is identical to an open reading frame (F38A6.3) that was predicted following determination of the *C. elegans* genome sequence, except for a 104 amino acid amino-terminal extension in the latter. No further ESTs or PCR products corresponding to the extension could be identified and RACE-PCR products contained a putative *trans* spliced leader sequence. These findings predict that F38A6.3 encodes a 719 amino acid polypeptide that lacks the proposed amino terminal extension (Supplemental Figure S1, available online at <http://www.cell.com/cgi/content/full/107/1/43/DC1>) and was named HIF-1. To avoid ambiguity, we have used the species descriptors *Hs* and *Ce* as prefixes to distinguish relevant human and *C. elegans* proteins and genes throughout the remainder of the manuscript.

To characterize the regulation of *C. elegans* HIF-1 (CeHIF-1), we raised antisera to a recombinant polypeptide, and immunoblotted worm extracts prepared from worms exposed to hypoxia, or the cell penetrating iron chelator 2, 2' dipyrpyridyl. Immunoblotting showed striking induction of CeHIF-1 by both stimuli. Induction by hypoxia was maximal at the lowest tested concentrations of 0.5% and 0.1% oxygen. In 0.1% oxygen, CeHIF-1 protein level was strongly induced within 4 hr, and sustained over 24 hr, but disappeared within minutes following reoxygenation (Figure 1A). In contrast, CeHIF-1 encoding mRNA levels were unchanged by hypoxia (data not shown). Thus, these experiments confirmed upregulation of CeHIF-1 by hypoxia, and suggested a mode of regulation at the protein level similar to that described for mammalian HIF- α subunits.

Critical Function of a VHL Homolog in the Regulation of CeHIF-1

We next compared CeHIF-1 expression in wild-type and a series of mutant worms that were selected because of potential relevance to previously proposed models for oxygen sensing and signal transduction in the mammalian HIF system (for review, see Semenza, 1999; Zhu and Bunn, 2001). These included mutants in the PTEN/insulin receptor/PI-3-kinase pathway (*daf-18*, *daf-2*, *age-1*), a mutant in a putative homolog of VHL (*vhl-1*), mutants affecting mitochondrial proteins (*mev-1*, *clk-1*, *gas-1*), a mutant that affects cytosolic catalase activity *ctl-1*, and others selected for resistance or sensitivity to oxidant stresses, but where the mutant gene is not yet characterized (*mev-2*, *mev-3*). Representative immunoblots are shown in Figure 1B. With the exception of *vhl-1* all mutant worms showed preserved regulation of CeHIF-1 protein levels. In contrast, the *vhl-1* worms showed high levels of CeHIF-1 in normoxia that were unregulated by oxygen. These results confirmed the proposed homology for *vhl-1* (Woodward et al., 2000), and indicated a conserved role for *C. elegans* VHL (CeVHL-1) in the response to hypoxia.

Interaction of CeHIF-1 with CeVHL-1 Is Regulated by Prolyl Hydroxylation

To address the mechanism of regulation of CeHIF-1 by CeVHL-1, we next tested for interaction between the two proteins. ³⁵S-methionine-labeled, haemagglutinin (HA)-tagged CeVHL-1 (HA.CeVHL-1) and CeHIF-1 were produced separately in vitro in coupled transcription translation reactions (IVTT) in reticulocyte lysate. IVTTs were then mixed and assayed for interaction by anti-HA immunoprecipitation. When produced in this way, the proteins did not interact. However, when recombinant CeHIF-1 was preincubated with worm extract, interaction was observed (Figure 2A).

To study this further, N-terminal truncations of CeHIF-1 linked to a Gal4 DNA binding domain were constructed. The Gal/CeHIF-1 fusion proteins were expressed in reticulocyte lysates, preincubated with worm extracts, and then tested for interaction with HA.CeVHL-1. These experiments demonstrated that while N-terminal truncations up to and including Gal/CeHIF-1 (590-719) were captured efficiently by HA.CeVHL-1, Gal/CeHIF-1(641-719) was not, implicating CeHIF-1 amino acids 590-641 in the interaction (Figure 2B). Inspection of this region revealed homology to VHL binding domains in *Hs*HIF-1 α that contain sites of prolyl hydroxylation (Ivan et al., 2001; Jaakkola et al., 2001; Masson et al., 2001) (Figure 2C). We therefore mutated the homologous prolyl residue in CeHIF-1 (P621→G) and found that this mutation ablated interaction with HA.CeVHL-1 (Figure 2D).

This suggested that the mechanism regulating the CeHIF-1/CeVHL-1 interaction through enzymatic prolyl hydroxylation might also be conserved in *C. elegans*. To test this, *N*-oxalyl-2S-alanine, a 2-oxoglutarate analog that inhibits this class of enzyme, was added to the worm extract during preincubation with HIF-1. Inhibition was observed that was competed by excess 2-oxoglutarate (Figure 2E). To test whether hydroxylation of the critical P621 residue in CeHIF-1 could indeed promote binding to CeVHL-1, we synthesized N-terminal biotinylated peptides corresponding to residues 607-634 of

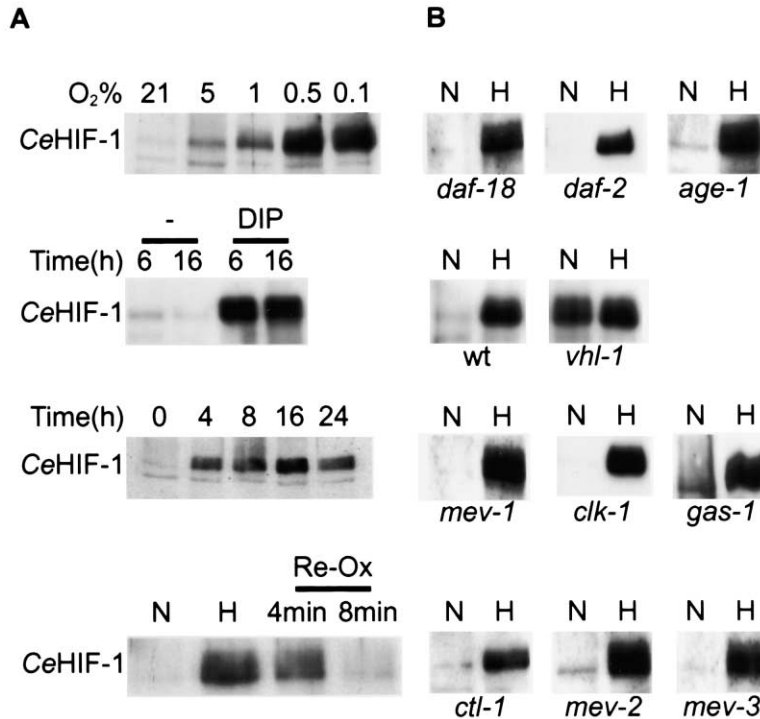

Figure 1. Regulation of CeHIF-1 in Wild-type and Mutant Worms

(A) Representative immunoblots showing induction of HIF-1 protein in worms exposed to the indicated oxygen levels for 16 hr or normoxic growth without (–) or with iron chelator 2'2'-dipyridyl, 200 μ M (DIP) for the indicated times. The time course of HIF accumulation on exposure to 0.1% O_2 is shown, as is the rapid reduction on reoxygenation with air (ReOx) following 16 hr of 0.1% hypoxia (H). (B) Immunoblots of HIF-1 protein in extracts prepared from wild-type (wt) or mutant worms. N, normoxia; H, hypoxia; for a period of 16 hr unless specified otherwise.

CeHIF-1 that contained either a proline (B28Pro) or a (2*S*,4*R*)-*trans*-hydroxyproline residue (B28Hyp) at position 621. B28Hyp, but not B28Pro blocked capture of pretreated CeHIF-1 by HA.CeVHL-1 when added to the interaction mix (Figure 2F). Furthermore, B28Hyp, but not B28Pro captured immunodetectable native CeVHL-1 from extracts of wild-type, but not *vhl-1* mutant worms (Figure 2G). Finally, to test the importance of prolyl hydroxylation in regulating CeHIF-1 in vivo, we exposed worms to the cell penetrating prolyl hydroxylase inhibitor, dimethylxalylglycine (Jaakkola et al., 2001). This strongly induced CeHIF-1 in normoxic worms (Figure 3A). These results demonstrated that conservation of the HIF/VHL system in *C. elegans* extends to the mode of regulation by prolyl hydroxylation.

The *C. elegans egl-9* Gene Product Is a Prototype HIF-PH

The best characterized prolyl hydroxylases are the procollagen modifying enzymes (Kivirikko and Myllyharju, 1998). However, worms containing inactivating mutations in each of two isoforms of the catalytic α -subunits, *dpy-18* (also termed *phy-1*) and *phy-2*, showed normal CeHIF-1 regulation, consistent with HIF-PH being distinct from the collagen modifying enzymes (Figure 3B). Based on the prediction that the HIF-PHs would belong to the 2-oxoglutarate-dependent oxygenase superfamily that possess a common β -barrel jelly roll motif, we searched *C. elegans* and mammalian databases for additional candidates that were well conserved between these species and conformed to the 2-oxoglutarate-dependent oxygenase archetype model. Of particular interest was a family of genes related to the *C. elegans* gene *egl-9*, a gene of previously unknown function that was first identified on the basis of an egg-laying abnor-

mal (*egl*) phenotype (Trent et al., 1983) (Figure 4). Sequence analyses coupled with secondary structure predictions in the light of crystallographic data (Zhang et al., 2000) predicted that these genes would encode a family of enzymes conserved in *C. elegans* and mammals. The predictions suggested that the enzymes would contain not only the jelly roll motif, but also conserved iron and 2-oxoglutarate binding residues in the same relationship that they occur in crystallographically characterized members of the family (e.g., the HXD...H iron binding motif on the second and seventh strands of the jelly roll motif).

Mutant worms containing defective *egl-9* alleles were analyzed for regulation of HIF-1. Three strains bearing inactivating mutant alleles of *egl-9*, (*sa307*, *sa330*, and *n571*) (Darby et al., 1999; Trent et al., 1983) all showed striking upregulation of CeHIF-1 in normoxia and loss of induction by hypoxia (Figure 3C). Moreover, a temperature-sensitive *egl-9* mutant, *n586*, showed enhanced normoxic CeHIF-1 levels at the nonpermissive temperature (Figure 3D). To determine the effect of EGL-9 on the CeHIF-1 transcriptional response, we measured mRNA levels of a range of hypoxia inducible transcripts and found striking upregulation in *egl-9* worms. Figure 3E shows data for a strongly inducible mRNA of unknown function (F22B5.4), that we have identified in gene array screens of *vhl-1* worms (A.E. and S. Kim, unpublished results). These findings demonstrated a critical function for EGL-9 in the regulation of CeHIF-1 and strongly suggested that EGL-9 might function as a HIF-PH that targets CeHIF-1 to CeVHL-1.

To test this, we produced recombinant EGL-9 and assessed its ability to catalyze the posttranslational modification of CeHIF-1. CeHIF-1 was captured efficiently by HA.CeVHL-1 after incubation with EGL-9 pro-

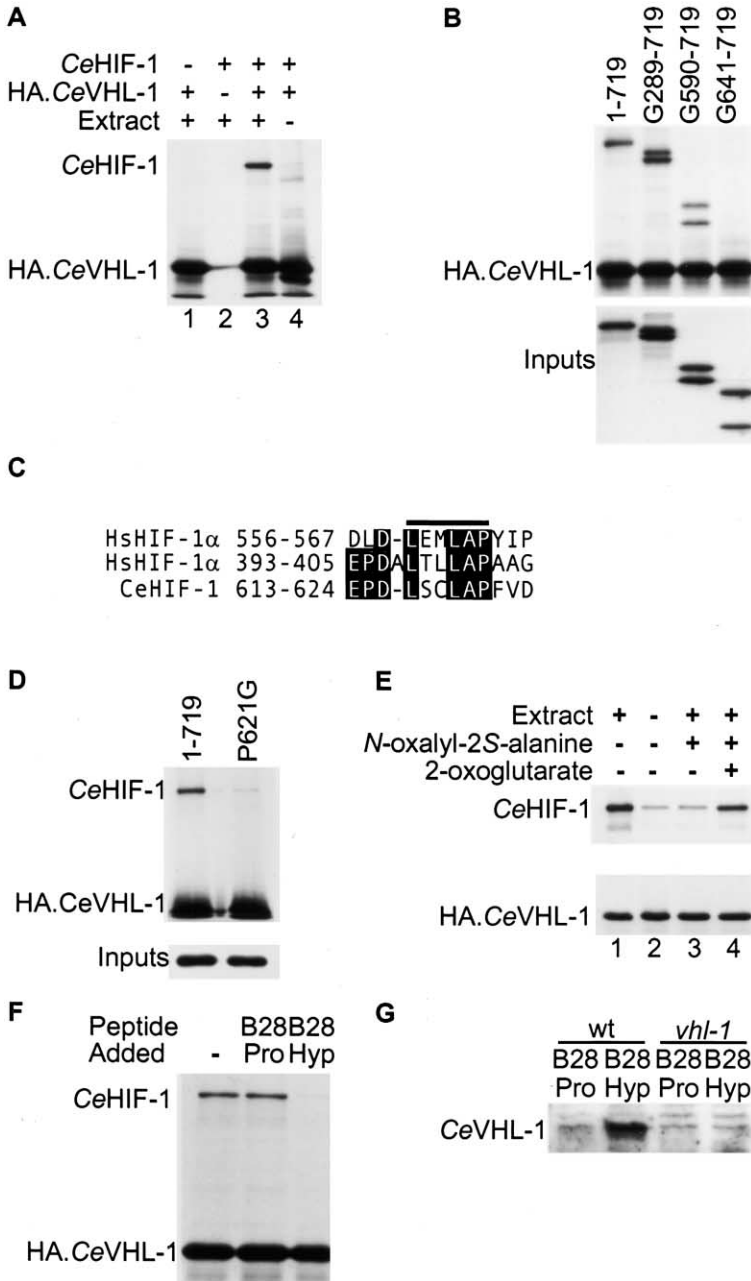

Figure 2. Interaction between CeHIF-1 and CeVHL-1 Is Regulated by Prolyl Hydroxylation

(A) Interaction between ^{35}S -labeled HA.CeVHL-1 and CeHIF-1 assayed by coimmunoprecipitation using anti-HA. Pretreatment of CeHIF-1 with worm extract promotes the interaction (compare lanes 3 and 4).

(B) Interaction between HA.CeVHL-1 and extract-treated CeHIF-1 or Gal/CeHIF-1 fusions (G) containing the indicated CeHIF-1 sequences. Upper panel, ^{35}S -labeled proteins captured by anti-HA immunoprecipitation; lower panel, inputs. Despite equivalent input, GalCeHIF-1(641-719) is not captured. Note, the additional GalCeHIF-1 species arise from an aberrant initiation site within the Gal sequences.

(C) Alignment of *C. elegans* CeHIF-1 sequences with VHL binding sites in mammalian HIF-1 α . Core LXXLAP motif is overlined.

(D) Mutation at CeHIF-1 prolyl residue 621 (P621G) ablates the interaction between extract-treated CeHIF-1 and HA.CeVHL-1.

(E) Effect of the 2-oxoglutarate analog N-oxalyl-2S-alanine (1 mM) on the ability of worm extract to promote interaction between CeHIF-1 and HA.CeVHL-1. Inhibition is antagonized by excess (5 mM) 2-oxoglutarate (compare lanes 3 and 4).

(F) Blocking of interaction between extract-treated CeHIF-1 and HA.CeVHL-1 by synthetic peptides corresponding to amino acids 607-634 of CeHIF-1. Peptide containing hydroxyproline at position 621 (B28Hyp) blocked the interaction effectively, whereas peptide containing proline at this position (B28Pro) did not.

(G) CeVHL-1 immunoblot of proteins captured from extract of wild-type (WT) or *vhl-1* mutant worms using streptavidin pull down of biotinylated peptides. Detection by rabbit anti-serum raised against CeVHL-1. B28Hyp, but not B28Pro captured native CeVHL-1.

grammed reticulocyte or wheat germ lysates, but not unprogrammed lysate (Figure 5A). In contrast, IVTTs expressing recombinant *C. elegans* PHY-1 (DPY-18), PHY-2, and the gene product of the predicted ORF T20B3.7, which also has significant homology to prolyl hydroxylases, had no activity in these assays (data not shown). To test whether EGL-9 could act directly on CeHIF-1, further preparations were made by baculoviral expression in insect cells and by expression as maltose binding protein (MBP) fusion proteins in *E. coli*. Since full-length MBP/EGL-9 protein was insoluble in *E. coli*, we prepared an N-terminal truncation containing residues 359-723 (MBP/ Δ N.EGL-9) that preserved the predicted catalytic domain and had CeHIF-1 modifying activity when expressed as an IVTT. CeHIF-1 substrates were made as

N-terminal Gal fusion proteins in either insect cells or *E. coli* and purified by anti-Gal immunoprecipitation. These substrates were incubated with lysates of insect cells expressing full-length EGL-9 or purified MBP/ Δ N.EGL-9, and tested for ability to capture CeVHL-1. Both forms of recombinant EGL-9 efficiently promoted modification of CeHIF-1 as indicated by HA.CeVHL-1 capture. Moreover, analysis of this activity demonstrated 2-oxoglutarate, iron, and oxygen dependence, and direct inhibition by cobaltous ions (Figures 5B and 5C).

To demonstrate that activity in the HA.CeVHL-1 capture assays corresponded to hydroxylation of the critical CeHIF-1 residue P621, we assayed modified CeHIF-1 polypeptides for 4-hydroxyproline content by HPLC. To provide larger quantities of protein for analysis, we co-

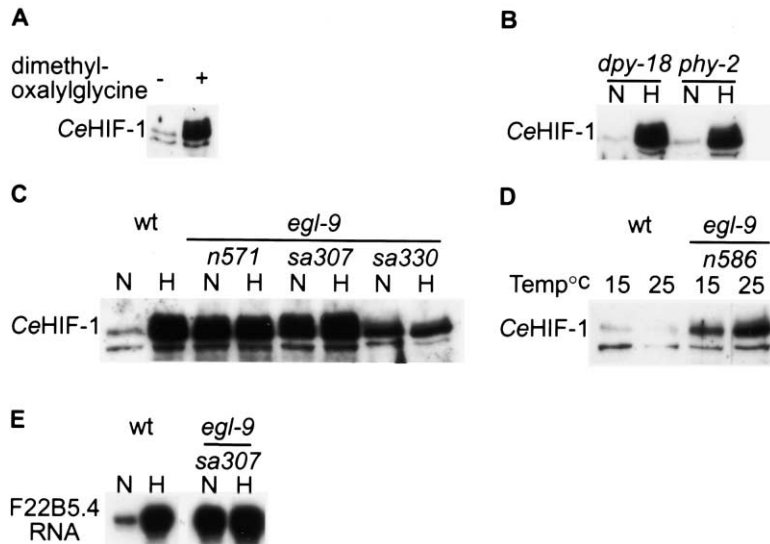

Figure 3. Prolyl Hydroxylation and the *egl-9* Gene Have a Critical Role in the Regulation of CeHIF-1

(A–D) Representative immunoblots of CeHIF-1 levels in worm extracts.

(A) Induction of CeHIF-1 in *C. elegans* by dimethyl-oxalylglycine (1 mM, 6 hr).

(B) CeHIF-1 levels in collagen-type prolyl hydroxylase mutant worms *dpy-18* and *phy-2*.

(C) CeHIF-1 levels in wild-type and *egl-9* mutants. Constitutive upregulation of CeHIF-1 is observed with all *egl-9* mutant alleles. Note that the lower total level of CeHIF-1 in the strain containing the *sa330* allele was a consistent finding, possibly indicating the existence of a modifying genetic influence on overall CeHIF-1 expression.

(D) CeHIF-1 protein levels in normoxic wild-type (WT) worms, and a temperature-sensitive *egl-9* mutant containing allele *n586*. Upregulation of CeHIF-1 is increased at the nonpermissive temperature (25°C) at which the egg laying abnormal phenotype is observed.

(E) Representative RNase protection assays of mRNA for the hypoxia-inducible transcript F22B5.4 in wild-type and *egl-9* mutant (*sa307*) worms.

transformed *E. coli* with wild-type or a P621→G mutant His₆/Gal/CeHIF-1(590-719) fusion protein and either MBP/ΔN.EGL-9 or MBP. His₆/Gal/CeHIF-1 substrates were retrieved by nickel affinity chromatography and aliquots assayed for ability to capture ³⁵S-methionine labeled HA.CeVHL-1 using anti-Gal immunoprecipitation, or subjected to acid hydrolysis and HPLC analysis for 4-hydroxyproline. In concordance with the HA.CeVHL-1 capture assay results, 4-hydroxyproline was produced in wild-type, but not mutant His₆/Gal/CeHIF-1 substrate after exposure to enzyme (Figure 5D). These results demonstrate the critical function of EGL-9 as a prolyl hydroxylase that targets CeHIF-1 to CeVHL-1 in *C. elegans*.

Identification of a Series of Mammalian HIF-PH Isoforms

Sequence similarity between EGL-9 and a rat gene product termed SM-20 has been noted previously, though no functional connection was recognized (Wax et al., 1994; Darby et al., 1999). Our sequence-structure search identified a larger series of homologies and predicted three related genes in each of the human and rodent genomes that bore striking homology to *egl-9*, particularly over the core putative catalytic domain. Figure 4 illustrates sequence alignment of EGL-9 (accession number AAD56365), rat SM-20 (accession number AAA19321), and the predicted human proteins defined by accession numbers XP_040482, AAG33965, and NP_071356, corresponding to Unigene clusters Hs.324277, Hs.6523, and Hs.18878. We provisionally termed the human protein products “prolyl hydroxylase domain containing” (PHD) 1, 2, and 3, respectively. Note that the gene we term PHD2 has previously been identified as a human homolog of rat SM-20 (Dupuy et al., 2000), though our alignment indicates that PHD3 has greater homology.

To test the role of these gene products in regulating

the interaction between HsHIF-α subunits and the HsVHL E3 ligase complex, we first produced the proteins by reticulocyte IVTT. Since unprogrammed lysate has low-level HIF-PH activity (Jaakkola et al., 2001), we tested for enhanced ability of the programmed lysates to promote the HsHIF-α/HsVHL E3 interaction. After incubation with relevant enzyme, HsHIF-α substrates were mixed with extracts from 786-0/VHL cells that stably express HA-tagged HsVHL, and tested for interaction by anti-HA immunoprecipitation. Figure 6A shows results for wild-type and mutant HsHIF-1α. With wild-type HsHIF-1α, striking activity was observed with rat SM-20 and all three human gene products, but not a mutant PHD1 bearing an H358A substitution at the predicted catalytic site, and not a different human 2-oxoglutarate dependent oxygenase (phytanoyl coenzyme A hydroxylase [Mukherji et al., 2001]) that was tested as a negative control. Similar results were obtained with HsHIF-2α (data not shown). Examination of HsHIF-1α mutants bearing missense substitutions at the critical prolyl residues in the HsHIF-1α ODDD (Masson et al., 2001) showed that enzymes were differentially efficient at promoting interaction via the C-terminal (P564) and N-terminal (P402) prolyl hydroxylation sites. Whereas interaction through the C-terminal site was promoted by all enzymes, HsVHL E3 capture was less efficient when only the N-terminal site (P402) was intact, and was only promoted by PHD1 and PHD2. No activity at all was observed with a double HsHIF-1α mutant, P402A P564G, that ablates both hydroxylation sites. In keeping with these results, all enzymes strongly promoted capture of HA.HsVHL by isolated HsHIF-1α sequences from the C-terminal site using a Gal/HsHIF-1α(549-582) fusion protein substrate and anti-Gal immunoprecipitation. Further analysis demonstrated that this activity was strongly inhibited by iron chelation, cobaltous ions, and the 2-oxoglutarate analog *N*-oxalylglycine (Figure 6B),

A

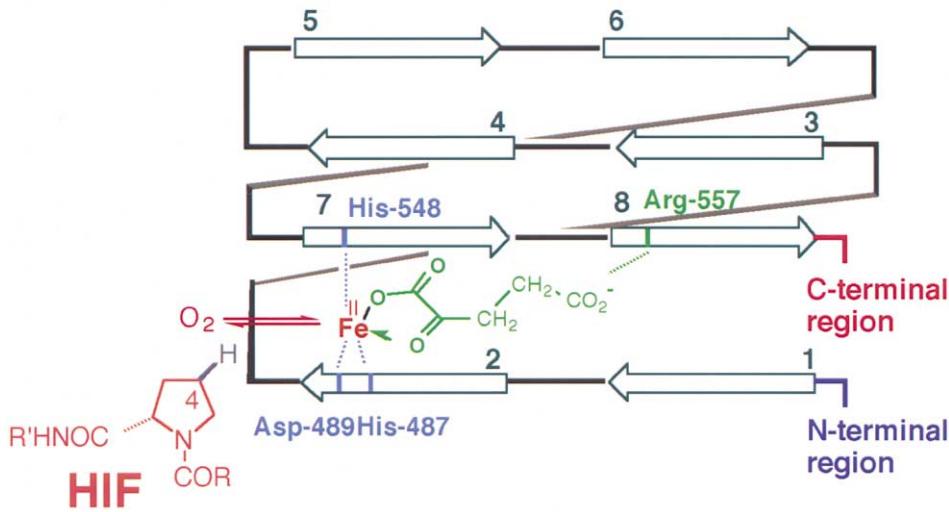

B

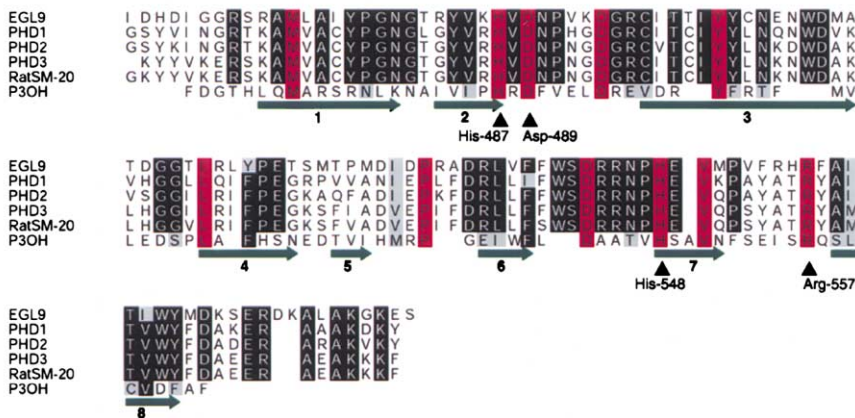

Figure 4. Predicted Conformation and Sequence Alignments for EGL-9 and Mammalian Homologs

(A) Topography diagram of the conserved jelly roll core (strands 1–8) of 2-oxoglutarate-dependent oxygenases, showing the approximate location of the conserved 2-histidine-1-carboxylate iron binding ligands, and 2-oxoglutarate binding basic residue (Arg-557), that were used to identify candidate HIF-PHs. Numbering refers to the position of these residues in the prototype, EGL-9.

(B) Sequence alignments of the predicted jelly roll cores of the HIF-PHs. Residues (as defined by the sequence depositions indicated in the text) are *C. elegans* EGL-9 (462–580); human PHD1 (272–386); human PHD2 (288–403); human PHD3 (111–225); and rat SM-20 (226–341). Also shown is the crystallographically determined secondary structure of *Streptomyces* sp. prolyl-3-hydroxylase (P30H) (I.C.Clifton, K.Harlos, C.J.S., and coworkers, unpublished results) that was used to model the analysis (Barton, 1993). Identical residues in all six proteins are colored in red, residues identical in five in black, and conserved residues in light gray. The eight strands of the jelly roll core are indicated in green. The residues of the 2-histidine-1-aspartate motif are indicated by arrows, as is the arginine proposed to bind the 5-carboxylate of 2-oxoglutarate (Mukherji et al., 2001).

though variation between enzymes was observed in the sensitivity to *N*-oxalylglycine and competition by excess 2-oxoglutarate. No capture of enzyme was observed in these immunoprecipitates, most probably reflecting the transient nature of the enzyme/substrate interaction.

To confirm direct action on *HsHIF-α* sequences, we prepared purified PHD-1 as an MBP fusion protein in *E.*

coli and assayed activity using either purified His-tagged *HsHIF-1α* polypeptides containing the N-terminal (344–503) or C-terminal (530–698) hydroxylation sites, or a synthetic peptide consisting of the minimal *HsHIF-1α* C-terminal substrate (B19Pro, residues 556–574). These experiments demonstrated activity by VHL capture assays, HPLC/MS detection of the hydroxylated peptide

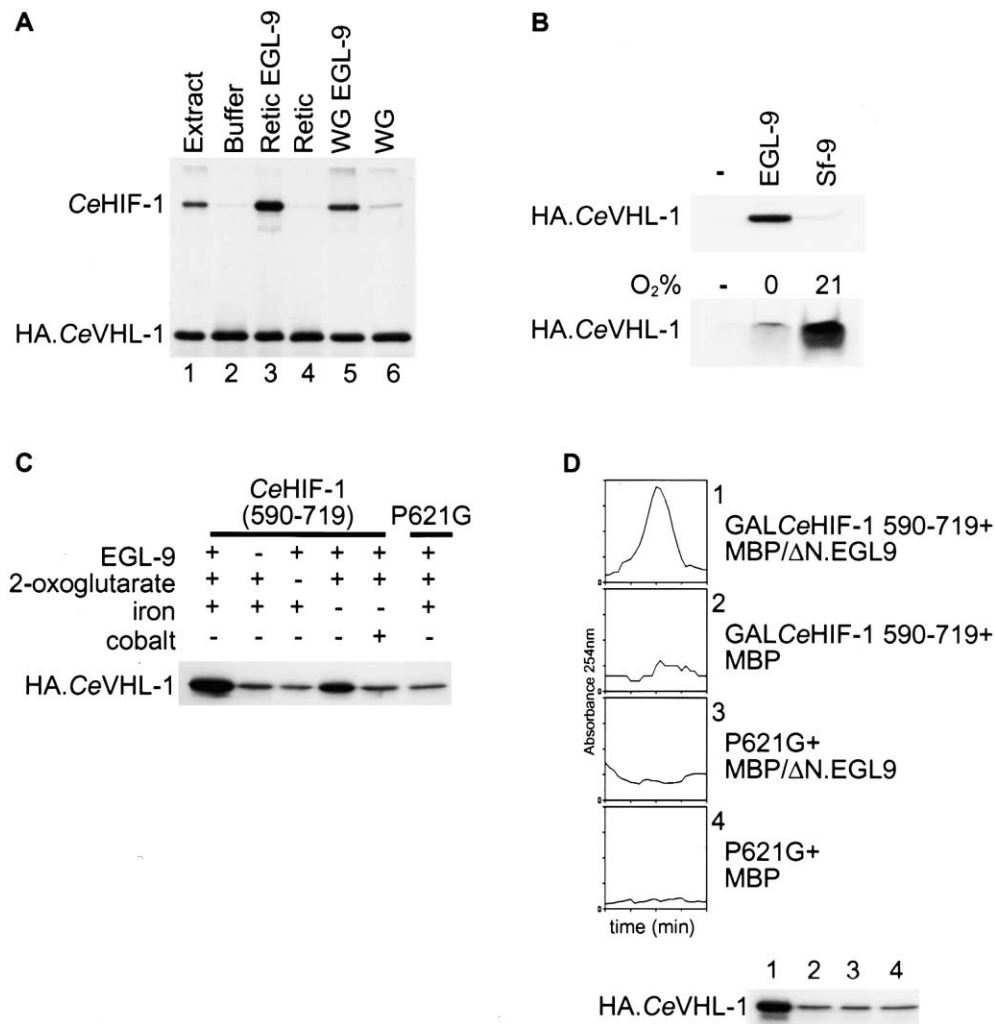

Figure 5. EGL-9 Regulates the Interaction of CeHIF-1 with CeVHL-1 by Prolyl Hydroxylation

(A) Modification of CeHIF-1 by EGL-9. ³⁵S-labeled CeHIF-1 and HA.CeVHL-1 were prepared in reticulocyte lysate. The CeHIF-1 was incubated with worm extract (lane 1), EGL-9 programmed reticulocyte (lane 3), or wheat germ (lane 5) lysate, or unprogrammed lysates (lanes 4 and 6), then mixed with HA.CeVHL-1 and assayed for interaction by coimmunoprecipitation using anti-HA.

(B) Effect of hypoxia on activity of EGL-9. Purified GalCeHIF-1(289-719) substrate was incubated with EGL-9 baculovirus-infected, or uninfected insect cell lysates, recaptured using anti-Gal beads, then assayed for ability to capture ³⁵S-labeled HA.CeVHL. Upper panel, EGL-9 infected but not uninfected lysate (Sf-9) modifies the GalCeHIF-1 substrate to promote capture of HA.CeVHL-1. Lower panel, reaction in anoxia suppresses activity of EGL-9.

(C) Effect of iron (100 μ M), 2-oxoglutarate (2 mM), and cobalt (100 μ M) on activity of recombinant EGL-9. Purified GalCeHIF-1(590-719) substrate was incubated with purified MBP/ Δ N.EGL9, and tested for ability to capture ³⁵S-labeled HA.CeVHL. Activity is dependent on 2-oxoglutarate, enhanced by iron, and inhibited by cobalt. Right hand lane, mutant GalCeHIF-1 (P621G) substrate. Note, some nonspecific HA.CeVHL capture is observed under these conditions (see also [D]).

(D) EGL-9 hydroxylates prolyl residue 621 in CeHIF-1. *E. coli* were cotransformed with a plasmid expressing either His₆GalCeHIF-1(590-719), or a mutant (P621G) derivative, and plasmids expressing MBP/ Δ N.EGL9 or MBP alone. Retrieved His₆CeGalHIF-1 was subject to HPLC analysis for 4-hydroxyproline (upper panel) or tested for ability to capture ³⁵S-labeled HA.CeVHL (lower panel).

product, or derivatized 4-hydroxyproline, and by 2-oxoglutarate decarboxylation assays (Figure 6C, and data not shown).

To verify expression of all three isoforms, we performed RNase protection analysis using riboprobes specific for each transcript. Since the rate of *Hs*HIF degradation in normoxia is enhanced by prior exposure of cells to a period of hypoxia (Berra et al., 2001), it has been predicted that HIF-PH would itself be induced by the transcriptional response to hypoxia. RNase protection showed that all three HIF-PH mRNAs are expressed

in HeLa cells and that in this cell line, transcripts for PHD2 and PHD3, but not PHD1 are induced by hypoxia (Figure 7A). In keeping with this, semiquantitative analysis of lysates prepared from HeLa cells that had been grown in normoxia or exposed to hypoxia for 16 hr, then assayed for HIF-PH activity in vitro using the *Hs*VHL capture assay, demonstrated induction of total HIF-PH activity that was blocked by actinomycin D (Figure 7B).

Finally, we used *Hs*VHL capture assays to measure the activity in vitro of recombinant PHD-1 on an *Hs*HIF-1 α 549-582 substrate at graded levels of hypoxia in a con-

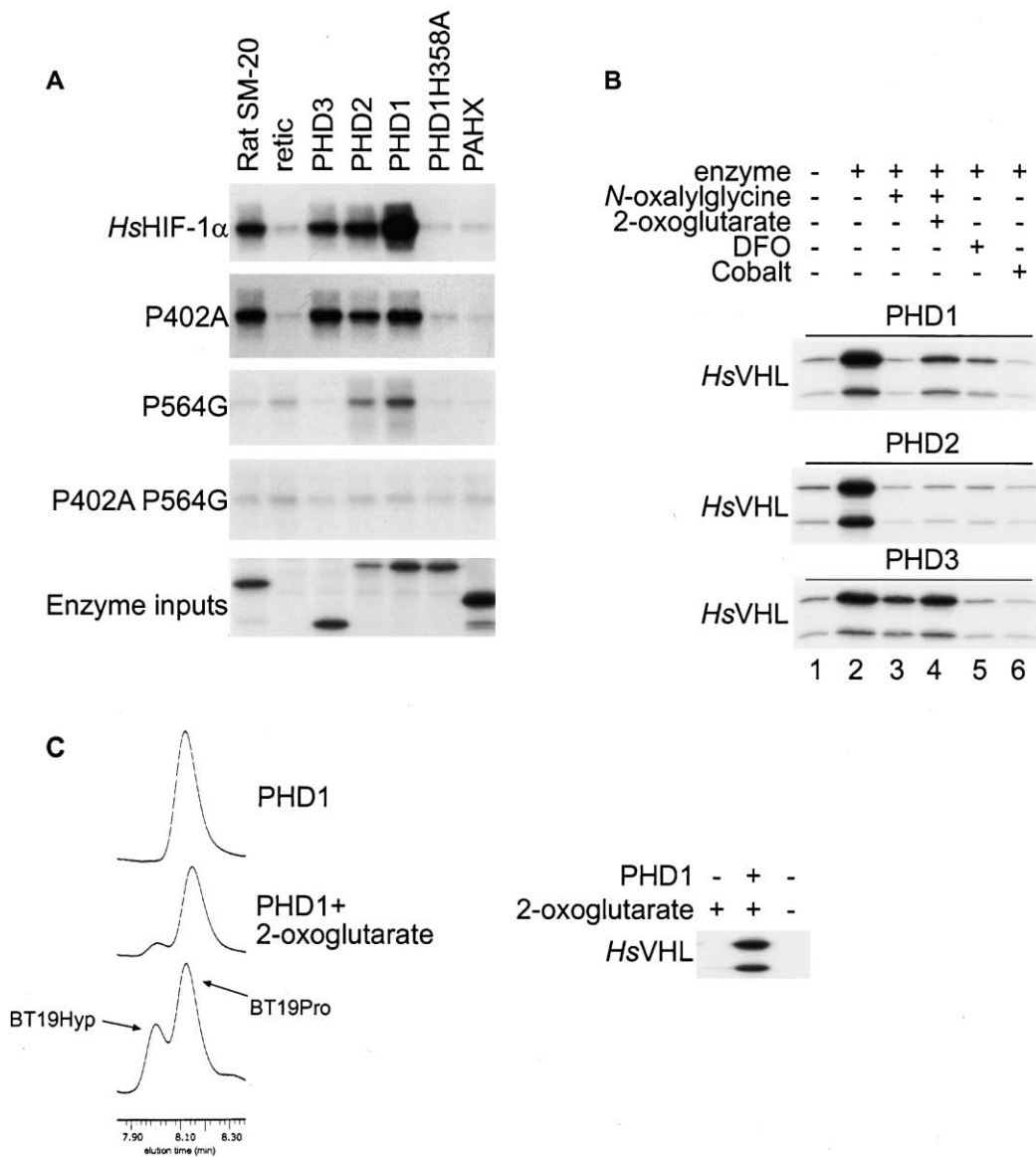

Figure 6. Interaction between *HsHIF- α* and *HsVHL* Is Regulated by a Series of HIF-PH Isoforms

(A) Recombinant HIF-PH isoforms modify *HsHIF-1 α* in a site-specific manner. Representative experiment showing capture of *HsHIF-1 α* by *HsVHL* E3. 35 S-labeled, full-length wild-type or mutant *HsHIF-1 α* substrates were produced by IVTT, and incubated with 35 S-labeled, full-length recombinant enzymes. Treated *HsHIF-1 α* was interacted with extracts from 786-0/VHL cells that stably express HA.*HsVHL*, and assayed for interaction by anti-HA immunoprecipitation. Upper panels; captured wild-type and mutant *HsHIF-1 α* substrates. Lowest panel; enzyme inputs. PAHX, phytanoyl coenzyme A hydroxylase. Note that under the conditions of assay, enzyme was not immunoprecipitated. Input *HsHIF-1 α* levels were equivalent (not shown).

(B) Activity of PHD-1, 2, and 3 assayed by *HsVHL* capture using *HsHIF-1 α* residues 549–582 as substrate. Representative capture assays showing the effect of the 2-oxoglutarate analog N-oxalylglycine (2 mM) and competition by additional 2-oxoglutarate (2 mM) (lanes 3 and 4). Effect of iron chelation, with desferrioxamine (DFO, 100 μ M) and cobalt (100 μ M) is shown in lanes 5 and 6.

(C) Hydroxylation of synthetic peptide by purified PHD1. Synthetic *HsHIF-1 α* (B19Pro) peptide was treated with MBP/PHD-1 in the presence or absence of 2-oxoglutarate. Left panel; HPLC traces. Lower trace shows positions of B19Pro and B19Hyp standards. Right panel; capture of *HsVHL*. Appearance of the hydroxylated peptide concurs with ability to interact with *HsVHL*. Note that the reaction did not go to completion. This was observed in other experiments and most likely represents self-inactivation of the enzyme under *in vitro* reaction conditions.

trolled hypoxia work station. We first measured the effect of graded hypoxia on the *HsHIF* modifying activity of extracts of *vhl*-defective RCC4 cells that contain a relatively high level of total HIF-PH activity. A progressive reduction in activity was observed with graded hypoxia (Figure 7C, upper panel). Similar assays were then

performed using PHD-1 produced in reticulocyte lysate by IVTT, or purified MBP/PHD-1 obtained by expression in *E. coli*. Similar progressive reductions in the activity of each preparation were observed with graded hypoxia (Figure 7C, lower panels). Thus, the activity of recombinant PHD-1 from either source parallels that observed

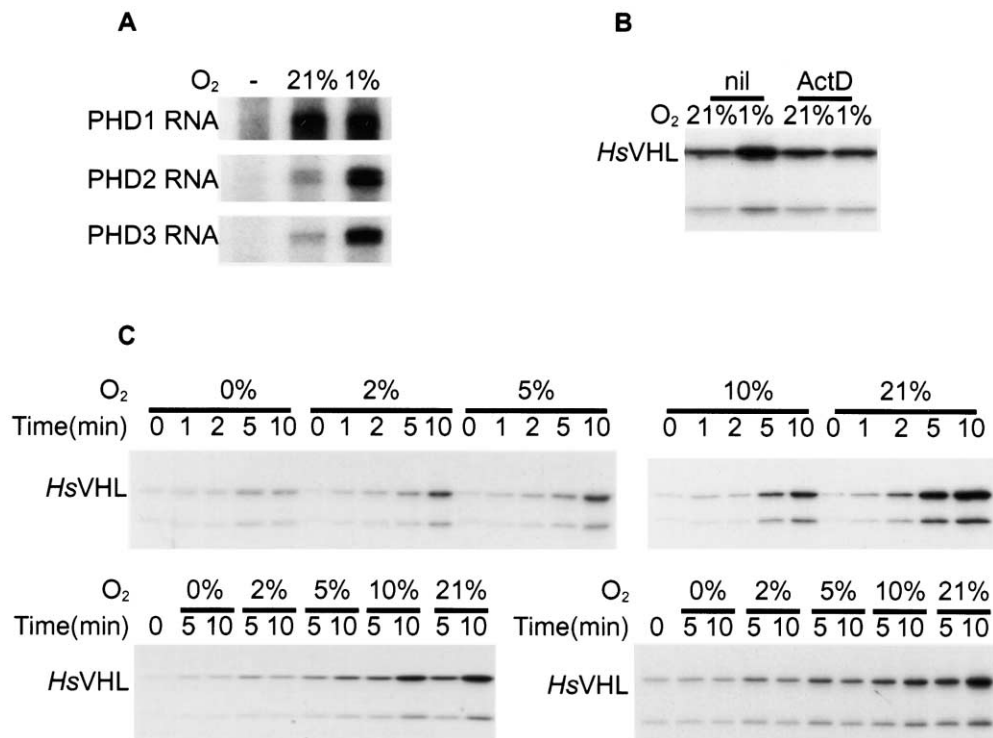

Figure 7. Regulation of HIF-PHs by Oxygen

(A) Representative RNase protection assays showing the effect of hypoxia (1% oxygen, 16 hr) on mRNA levels for PHD1, PHD2, and PHD3 in HeLa cells. Fifty micrograms total RNA was assayed; left hand lane (-) is a no RNA control.

(B) Effect of 4 hr hypoxia and actinomycin D (1 μ M final concentration, added 30 min prior to 4 hr hypoxic exposure) on total HIF-PH activity in HeLa cells. Activity of extracts prepared from the HeLa cells (250 μ g of protein in 50 μ l) was measured as the ability to modify purified Gal/HsHIF-1 α 549-582/VP16 substrate in vitro to promote capture of 35 S-labeled HsVHL. Reactions were performed in air.

(C) Representative experiment showing the effect of graded hypoxia on HIF-PH activity in vitro. Activity was measured by HsVHL capture assays using purified Gal/HsHIF-1 α 549-582/VP16 substrate as above. Reactions were performed in the indicated atmospheric oxygen concentrations in a hypoxia workstation. Upper panels, activity of cell extracts prepared from RCC4 cells cultured in normoxia; lower left panel, activity of PHD-1 expressed in reticulocyte lysate IVTT; lower right panel, activity of purified bacterially expressed MBP/PHD-1.

in crude cell extracts, in respect of oxygen-dependent modulation.

Discussion

Recent work in mammalian cells has demonstrated that posttranslational modification by prolyl hydroxylation targets HIF- α to the VHL ubiquitylation complex leading to rapid proteasomal degradation (Ivan et al., 2001; Jaakkola et al., 2001). Characterization of the modifying activity in cell extracts predicted that the relevant enzyme(s) would belong to the 2-oxoglutarate-dependent oxygenase superfamily—the requirement for dioxygen as cosubstrate suggesting a function in cellular oxygen sensing. Here, we demonstrate the existence of a homologous HIF-VHL-prolyl hydroxylase system in *C. elegans*, and use a genetic approach to identify a novel functional group of 2-oxoglutarate-dependent oxygenases that function as HIF-PHs. The critical role of this process in the regulation of HIF is emphasized by analysis of *vhl-1* and *egl-9* mutant worms, which show essentially complete loss of regulation of CeHIF-1 by oxygen.

Secondary structural analysis predicts that the HIF-PHs fold to produce a common jelly roll structure that positions a nonheme-iron coordinating HXD...H motif at

the catalytic site. Kinetic and time-resolved crystallographic studies of the catalytic mechanism among members of this class of oxygenase have indicated ordered binding of iron (II), 2-oxoglutarate, and prime substrate (Zhang et al., 2000; Zhou et al., 1998). Binding of the latter “primes” the enzyme for reversible binding of dioxygen, probably by displacing a water molecule from the iron. Weak binding at the iron center is associated with a cofactor requirement for iron (II). In keeping with this, we found that the activity of the recombinant enzyme required iron, and was directly inhibited by cobaltous ions, probably by substitution at the iron center. Moreover, we found that a mutation (PHD1; H358A) that is predicted to abrogate iron binding, but not otherwise alter the three-dimensional structure (Lloyd et al., 1999), completely ablated enzyme activity. By conducting reactions in a controlled oxygen environment, we showed that the activity of the purified enzyme was strikingly sensitive to graded levels of hypoxia in vitro. Though unknown intracellular oxygen gradients make direct comparison subject to some uncertainty, these findings mirror the progressive increases in HIF-1 α protein and DNA binding that are observed when cells are exposed to graded hypoxia in culture (Jiang et al., 1996).

Thus, the classical features of HIF induction by hyp-

oxia, cobaltous ions, and iron chelators can be explained, at least qualitatively, by the properties of recombinant HIF-PH enzymes. Whether the characteristics of these enzymes can explain other described responses of the HIF system is less clear. The hydroxylation section of the catalytic mechanism is believed to proceed by a radical rebound mechanism (Lloyd et al., 1999; Wu et al., 1999), and may be relevant to different reported effects of reactive oxygen species on HIF regulation (for review, see Semenza, 1999; Zhu and Bunn, 2001). Furthermore, the ability of nitric oxide (NO) to bind to enzyme-iron (II)-2-oxoglutarate complexes of this class (Z.H. Zhang, C.J.S., and coworkers, unpublished results) may be relevant to the reported effects of NO donors on HIF regulation (Huang et al., 1999; Palmer et al., 2000). The availability of recombinant HIF-PHs will now permit direct testing of these possibilities, and an important challenge will be to determine the extent to which the complex demands of physiological oxygen homeostasis are met by the biochemical properties of these enzymes.

Identification of the HIF system in nematode worms that obtain oxygen by diffusion reveals that the system must have evolved before the development of complex systemic oxygen delivery systems, presumably to regulate responses to oxygen availability at the cellular level. In keeping with these simpler requirements, the HIF system appears to be less complex in *C. elegans* than in mammals. Complete loss of CeHIF-1 regulation in *egl-9* mutants suggests that there may be only one HIF-PH in worms, and we have so far defined only one site of hydroxylation in a single HIF- α homolog. Furthermore, in the survey of mutant worms, we were unable to demonstrate major interactions with oxygen radical metabolism such as have been proposed in mammalian cells.

Definition of this mechanism of proteolytic targeting by prolyl hydroxylation and the frequent occurrence of prolyl residues in short-lived proteins raises the question as to whether these enzymes have a broader role in proteolytic targeting or signaling. Though we found that *C. elegans* and mammalian enzymes were not functionally interchangeable (data not shown), implying some differences in substrate selectivity, the existence of a conserved LXXLAP motif at the hydroxylation sites may help define other targets. In this respect, it is of interest that *C. elegans egl-9* and the mammalian HIF-PH, SM-20 have been identified previously in different contexts. The SM-20 gene was first identified as a transcript induced by platelet-derived growth factor stimulation in rat smooth muscle cells (Wax et al., 1994), and subsequently, as a gene that is functionally involved in apoptosis and growth regulation (Lipscomb et al., 2001; Madden et al., 1996). Interestingly, these studies have shown that SM-20 immunoreactivity is localized in part to the mitochondrion (Lipscomb et al., 2001). In *C. elegans*, *egl-9* was first identified as a gene responsible for an egg-laying defect (Trent et al., 1983). Subsequently, further *egl-9* mutants were isolated in a screen for worms resistant to a *Pseudomonas aeruginosa* toxin (Darby et al., 1999). Whether these functions relate to effects on the HIF system or other prolyl hydroxylation targets is unclear. However, despite similar upregulation of the HIF system in *vhl-1* and *egl-9* mutant worms, the *vhl-1* worms do not manifest an egg laying defective phenotype, suggesting the existence of nonoverlapping func-

tions. Interestingly, EGL-9 possesses an N-terminal zinc finger domain that we have shown is unnecessary for HIF-PH activity and may have other functions.

Given the lethal effects of *HsVHL* and *HsHIF-1 α* disruption on mammalian development, it is of interest that *vhl-1* and *egl-9* worms are viable. *Hif-1* mutant worms are also viable under laboratory conditions, though defective in their ability to withstand hypoxia (Jiang et al., 2001). The availability of mutant worms at each level in the pathway should help define the overlapping and nonoverlapping functions of CeHIF-1, the tumor suppressor homolog CeVHL-1, and the prolyl hydroxylase EGL-9.

In mammals, the HIF system regulates not only cellular responses to oxygen, but also a range of systemic functions such as regulation of angiogenesis, erythropoiesis, and vasomotor control. These complex requirements have argued against the concept of a single oxygen sensor. However, the existence in mammalian cells of (at least) three isoforms of HIF-PH, and (at least) two isoforms of HIF- α each with more than one site of prolyl hydroxylation (Masson et al., 2001), provides the potential for differently tuned physiological responses to oxygen availability. Furthermore, previous studies of rat SM-20 have demonstrated regulation at the mRNA level by stimuli that include p53 activation, and exposure to a variety of growth factors (Madden et al., 1996; Wax et al., 1994). Since these oxygenases are nonequilibrium enzymes, changes in the level of enzyme will affect the potential rate of HIF hydroxylation, as was suggested by the effects of hypoxia on mRNA levels and total HIF-PH activity in HeLa cells. Such additional controls over HIF activity may provide feedback, and may also influence the interactions between oxygen availability and nonhypoxic stimulation of HIF by growth factors and cytokines (reviewed in Maxwell et al., 2001).

Finally, the identification of the HIF-PHs also raises therapeutic possibilities. Inhibitors of HIF-PHs might be used to activate HIF and enhance angiogenesis in ischemic/hypoxic disease. Application of the 2-oxoglutarate analog dimethyloxalylglycine to tissue culture cells strongly induces HIF target genes (D.R.M., unpublished observations). Though this compound is not specific for the HIF-PHs and inhibits other 2-oxoglutarate dioxygenases, structural and mechanistic studies of the defined enzymes may now permit design of more specific inhibitors for therapeutic development.

Experimental Procedures

C. elegans Culture, Strains, and Extract Preparation

Worms were cultured using standard methods. Exposure to hypoxia was in bell jars gassed with humidified air or certified nitrogen/oxygen mixes (British Oxygen Company). Exposure to 2,2 dipyridyl (200 μ M), or dimethyloxalylglycine (1 mM) was performed in liquid medium. Wild-type worms were Bristol strain (N2). Mutant strains were obtained from the Caenorhabditis Genetics Centre or the originators, and are as indicated in Supplemental Table S1 (available online at <http://www.cell.com/cgi/content/full/107/1/43/DC1>). A deletion mutant in the *vhl-1* gene (*ok161*) was generated using trimethylpsoralen. The *vhl-1* strain CB5603 was constructed by backcrossing *ok161* two times against wild-type (N2), then constructing a triple mutant with markers on either side of *vhl-1* (genotype: *dpy-6* (e2562) *vhl-1* (*ok161*) *unc-9* (*e101*)), and then removing these markers by further crosses against N2.

Worm extracts were prepared by homogenization (Ultraturax T20, IKA Labortechnik) in 4 volumes extraction buffer (150 mM NaCl, 1 mM EDTA, 50 mM Tris [pH 7.5], 1% NP-40, and 1% sodium deoxycholate) for immunoblotting, or in 2 volumes of hypotonic extraction buffer, HEB (20 mM Tris [pH 7.5], 5 mM KCl, 1.5 mM MgCl₂, and 1 mM DTT) for modification reactions. Forty micrograms of extract was used for immunoblots and 150 μg used in modification reactions.

Mammalian Cells and Extract Preparation

HeLa and RCC4 cells were cultured in DMEM. Cell extracts were prepared in HEB.

Antibodies

Antisera to CeHIF-1 and CeVHL-1 were produced in rabbits immunized with either a glutathione-S-transferase fusion protein expressing amino acids 360–498 of CeHIF-1, or a maltose binding protein fusion linked to full-length (1–174) CeVHL-1. Mouse anti-HA antibody was 12CA5 (Roche), and mouse anti-Gal antibody was RK5C1 (Santa Cruz).

RNA Analysis

Details of riboprobe templates are provided in Supplemental Table S2 (available online at <http://www.cell.com/cgi/content/full/107/1/43/DC1>). RNA was prepared from a mixed population of worms using Tri-Reagent (Sigma), or from HeLa cells using RNazolB (Biogenesis). Thirty micrograms was used for each assay.

Plasmids

C. elegans cDNAs

The *C. elegans hif-1* cDNA was assembled from 4 overlapping cDNA clones, yk510h7, yk4a2, yk383g1, and yk272d11 (Y. Kohara, National Institute of Genetics, Japan), and inserted into pcDNA1AMP (Invitrogen). The *C. elegans vhl-1* cDNA and the cDNA encoding the predicted ORF of T20B3.7 were obtained by RT-PCR of worm RNA and inserted into pcDNA3 (with linkers that encoded an N-terminal HA tag), and pSP72 (Promega), respectively. The *egl-9* cDNA was subcloned into pcDNA1 from yk130h5 (Y. Kohara). *Phy-1* (*Dpy-18*) and *phy-2* cDNAs in pCR-Script were provided by Anthony Page, University of Glasgow, Scotland, UK. Gal/CeHIF-1 fusion proteins were generated by PCR and inserted into pcDNA3Gal (O'Rourke et al., 1999).

For insect cell expression, sequences encoding Gal/CeHIF-1(289–790) and EGL-9 (1–723) were subcloned into pFastBac1 (Gibco BRL). For bacterial expression, sequences encoding Gal/CeHIF-1(590–790) and EGL-9 (359–723) were subcloned into pET-28a (Novagen), and pMAL-p2X (NEB), respectively.

Mammalian cDNAs

The cDNAs encoding the human polypeptides designated PHD1, PHD2, and PHD3 were obtained by PCR amplification and/or restriction endonuclease digestion from publicly available cDNA banks (I.M.A.G.E consortium, and NEDO human cDNA sequencing project), or a human colonic cDNA library. Products were ligated into pcDNA3 for expression in reticulocyte lysate IVTTs, or into pMAL-p2X for expression in *E. coli* as maltose binding protein fusions. pPDS15 (Lipscomb et al., 2001) (provided by R. Freeman, University of Rochester, Rochester, NY) was used for expression of rat SM-20 in reticulocyte lysate IVTT; sequences encoding amino acids 60–355 were subcloned into pTYB11 (NEB) for expression in *E. coli*.

For bacterial expression, human HIF-1α sequences encoding amino acids 344–503 or 530–698 were subcloned into pET28a.

Mutations were generated using a site-directed mutagenesis system (Stratagene). All plasmid sequences were verified by DNA sequencing.

Protein Expression

³⁵S-labeled or unlabeled proteins were generated in TNT reticulocyte lysate or wheat germ lysate (Promega). Protein expression in insect cells was performed using the Bac-to-Bac/St9 system (Gibco BRL). Bacterially expressed proteins were produced in *E. coli* strain BL21 (DE3). Proteins were used in lysates or purified using amylose resin, DEAE-Sepharose, nickel affinity chromatography, or anti-Gal antibodies, as appropriate.

Interaction Assays

Assays for interaction between recombinant VHL and HIF polypeptides conformed to the following experimental design: Recombinant VHL and HIF polypeptides were produced separately *in vitro*. The HIF polypeptide was then preincubated with extract or a recombinant enzyme as indicated, then mixed with VHL and incubated in EBC buffer (50 mM Tris [pH 7.5], 150 mM NaCl, 0.5% v/v Igepal, and 0.5 mM EDTA) at 4°C for 1 hr, before immunoprecipitation with anti-HA antibodies (for HA tagged VHL) or anti-Gal antibodies (for GalHIF fusions) and analysis by PAGE.

Preincubation of CeHIF-1 with worm extract or recombinant EGL-9 was for 30 min at 25°C. Preincubation of HsHIF-α polypeptides with cell extract or recombinant enzymes was at 37°C for 10–30 min unless otherwise stated. For assays of recombinant enzymes, 2-oxoglutarate (2 mM), iron (100 μM), and ascorbate (2 mM) were added to the reaction buffer unless otherwise indicated. Reactions performed in hypoxia were in the stated atmospheric oxygen concentration (balance nitrogen), obtained using a controlled environment Invivo₂ 400 hypoxia workstation (Ruskin Technologies), and buffers preequilibrated with the appropriate atmosphere. Reactions (50 μl) were performed in open Eppendorf tubes with mixing and stopped by the addition of 20 volumes desferrioxamine (100 μM).

For peptide blocking experiments, CeVHL-1 was preincubated with peptides (1 μM final) for 15 min before addition to the interaction.

For VHL capture assays using synthetic biotinylated HsHIF-1α peptides, peptide was preincubated as indicated for 30 min at 37°C, then bound to streptavidin beads, washed, mixed with recombinant HsVHL or extract, recaptured using beads, and bound HsVHL analyzed by PAGE.

For HsHIF-1α capture assays using 786-0/VHL cell extract, HsHIF-1α polypeptides were produced by IVTT, preincubated with enzyme, then interacted with cell extract under conditions (10 mM Tris [pH 7.5], 0.25 M NaCl, and 0.5% NP40, at 4°C) that do not permit modification of HsHIF-1α (Masson et al., 2001), then immunoprecipitated with anti-HA, and analyzed by PAGE.

HPLC Analyses

Hydroxylation of the HsHIF-1α peptide B19Pro (residues 556–574) was analyzed by reverse phase HPLC using a C-18 (octadecylsilane) column and water/acetonitrile 0.1% TFA as the mobile phase. Standards were unmodified B19Pro and a synthetic peptide (B19Hyp) bearing a hydroxyproline substitution at Pro564.

For analysis of hydroxyproline, peptides or proteins were subject to acid hydrolysis, derivatization with phenylisothiocyanate and HPLC using standard methods. Decarboxylation assays were performed using 1-[¹⁴C]-2-oxoglutarate, purified polypeptide substrates at approximately 25 μM, and a purified MBP/PHD1 fusion as described (Mukherji et al., 2001).

Acknowledgments

This work was funded principally by the Wellcome Trust, the MRC and the BBSRC. A.C.R.E. received fellowships from the British Heart Foundation and BUPA. The authors are grateful to R.T. Aplin, M. Caines, I.C. Clifton, J. Elkins, S. Kim, L.G. Nicholls, A.C. Willis, and K.M. Yeates for contributions to the work, and R.S. Freeman, W.G. Kaelin, Jr., J. Kimble, Y. Kohara, C. Manoil, and A. Page for provision of reagents.

Received July 30, 2001; revised September 6, 2001.

References

- Barton, G.J. (1993). ALSCRIPT: a tool to format multiple sequence alignments. *Prot. Eng.* 6, 37–40.
- Berra, E., Richard, D.E., Gothie, E., and Pouyssegur, J. (2001). HIF-1-dependent transcriptional activity is required for oxygen-mediated HIF-1α degradation. *FEBS Lett.* 491, 85–90.
- Cockman, M.E., Masson, N., Mole, D.R., Jaakkola, P., Chang, G.W., Clifford, S.C., Maher, E.R., Pugh, C.W., Ratcliffe, P.J., and Maxwell, P.H. (2000). Hypoxia inducible factor-α binding and ubiquitylation

- by the von Hippel-Lindau tumor suppressor protein. *J. Biol. Chem.* **275**, 25733–25741.
- Darby, C., Cosma, C.L., Thomas, J.H., and Manoil, C. (1999). Lethal paralysis of *Caenorhabditis elegans* by *Pseudomonas aeruginosa*. *Proc. Natl. Acad. Sci. USA* **96**, 15202–15207.
- Dupuy, D., Aubert, I., Duperat, V.G., Petit, J., Taine, L., Stef, M., Bloch, B., and Arveiler, B. (2000). Mapping, characterization, and expression analysis of the SM-20 human homologue, c1orf12, and identification of a novel related gene, SCAND2. *Genomics* **69**, 348–354.
- Hegg, E.L., and Que, L. (1997). The 2-His-1-carboxylate facial triad—an emerging structural motif in mononuclear non-heme iron (II) enzymes. *Eur. J. Biochem.* **250**, 625–629.
- Huang, L.E., Gu, J., Schau, M., and Bunn, H.F. (1998). Regulation of hypoxia-inducible factor 1 α is mediated by an oxygen-dependent domain via the ubiquitin-proteasome pathway. *Proc. Natl. Acad. Sci. USA* **95**, 7987–7992.
- Huang, L.E., Willmore, W.G., Gu, J., Goldberg, M.A., and Bunn, H.F. (1999). Inhibition of hypoxia-inducible factor 1 activation by carbon monoxide and nitric oxide. *J. Biol. Chem.* **274**, 9038–9044.
- Ivan, M., Kondo, K., Yang, H., Kim, W., Valiando, J., Ohh, M., Salic, A., Asara, J.M., Lane, W.S., and Kaelin, W.G., Jr. (2001). HIF α targeted for VHL-mediated destruction by proline hydroxylation: implications for O₂ sensing. *Science* **292**, 464–468.
- Jaakkola, P., Mole, D.R., Tian, Y.-M., Wilson, M.I., Gielbert, J., Gaskell, S.J., Kriegsheim, A.v., Hebestreit, H.F., Mukherji, M., Schofield, C.J., Maxwell, P.H., Pugh, C.W., and Ratcliffe, P.J. (2001). Targeting of HIF- α to the von Hippel-Lindau ubiquitylation complex by O₂-regulated prolyl hydroxylation. *Science* **292**, 468–472.
- Jiang, B.-H., Semenza, G.L., Bauer, C., and Marti, H.H. (1996). Hypoxia-inducible factor 1 levels vary exponentially over a physiologically relevant range of O₂ tension. *Am. J. Phys.* **271**, C1172–C1180.
- Jiang, H., Guo, R., and Powell-Coffman, J.A. (2001). The *Caenorhabditis elegans hif-1* gene encodes a bHLH-PAS protein that is required for adaptation to hypoxia. *Proc. Natl. Acad. Sci. USA* **98**, 7916–7921.
- Kamura, T., Sato, S., Iwai, K., Czyzyk-Krzeska, M., Conaway, R.C., and Conaway, J.W. (2000). Activation of HIF1 α ubiquitination by a reconstituted von Hippel-Lindau (VHL) tumor suppressor complex. *Proc. Natl. Acad. Sci. USA* **97**, 10430–10435.
- Kivirikko, K.I., and Myllyharju, J. (1998). Prolyl 4-hydroxylases and their protein disulfide isomerase subunit. *Matrix Biol.* **16**, 357–368.
- Lipscomb, E.A., Sarmiere, P.D., and Freeman, R.S. (2001). SM-20 is a novel mitochondrial protein that causes caspase-dependent cell death in nerve growth factor-dependent neurons. *J. Biol. Chem.* **276**, 5085–5092.
- Lloyd, M.D., Lee, H.J., Harlos, K., Zhang, Z.H., Baldwin, J.E., Schofield, C.J., Charnock, J.M., Garner, C.D., Hara, T., Scheltinga, A.C.T., et al. (1999). Studies on the active site of deacetoxycephalosporin C synthase. *J. Mol. Biol.* **287**, 943–960.
- Madden, S.L., Galella, E.A., Riley, D., Bertelsen, A.H., and Beaudry, G.A. (1996). Induction of cell growth regulatory genes by p53. *Cancer Res.* **56**, 5384–5390.
- Masson, N., Willam, C., Maxwell, P.H., Pugh, C.W., and Ratcliffe, P.J. (2001). Independent function of two destruction domains in hypoxia-inducible factor- α chains activated by prolyl hydroxylation. *EMBO J.* **20**, 5197–5206.
- Maxwell, P.H., Wiesener, M.S., Chang, G.-W., Clifford, S.C., Vaux, E.C., Cockman, M.E., Wykoff, C.C., Pugh, C.W., Maher, E.R., and Ratcliffe, P.J. (1999). The tumour suppressor protein VHL targets hypoxia-inducible factors for oxygen-dependent proteolysis. *Nature* **399**, 271–275.
- Maxwell, H.P., Pugh, C.W., and Ratcliffe, P.J. (2001). Activation of the HIF pathway in cancer. *Curr. Opin. Genet. Dev.* **11**, 293–299.
- Mukherji, M., Kershaw, N.J., MacKinnon, C.H., Clifton, I.J., Wierzbicki, A.S., Schofield, C.J., and Lloyd, M.D. (2001). Chemical co-substrate rescue of phytanoyl-CoA 2-hydroxylase mutants causing Refsum's Disease. *Chem. Comm.* **11**, 972–973.
- O'Rourke, J.F., Tian, Y.-M., Ratcliffe, P.J., and Pugh, C.W. (1999). Oxygen-regulated and transactivating domains in endothelial PAS protein 1: comparison with hypoxia inducible factor-1 alpha. *J. Biol. Chem.* **274**, 2060–2071.
- Ohh, M., Park, C.W., Ivan, M., Hoffman, M.A., Kim, T.Y., Huang, L.E., Pavletich, N., Chau, V., and Kaelin, W.G. (2000). Ubiquitination of hypoxia-inducible factor requires direct binding to the beta-domain of the von Hippel-Lindau protein. *Nat. Cell Biol.* **2**, 423–427.
- Palmer, L.A., Gaston, B., and Johns, R.A. (2000). Normoxic stabilization of hypoxia-inducible factor-1 expression and activity: redox-dependent effect of nitrogen oxides. *Mol. Pharmacol.* **58**, 1197–1203.
- Salceda, S., and Caro, J. (1997). Hypoxia-inducible factor 1 α (HIF-1 α) protein is rapidly degraded by the ubiquitin-proteasome system under normoxic conditions. *J. Biol. Chem.* **272**, 22642–22647.
- Schofield, C.J., and Zhang, Z. (1999). Structural and mechanistic studies on 2-oxoglutarate-dependent oxygenases and related enzymes. *Curr. Opin. Struct. Biol.* **9**, 722–731.
- Semenza, G.L. (1999). Perspectives on oxygen sensing. *Cell* **98**, 281–284.
- Semenza, G. (2000a). HIF-1 and human disease: one highly involved factor. *Genes Dev.* **14**, 1983–1991.
- Semenza, G.L. (2000b). HIF-1: mediator of physiological and pathophysiological responses to hypoxia. *J. Appl. Physiol.* **88**, 1474–1480.
- Sutter, C.H., Laughner, E., and Semenza, G.L. (2000). Hypoxia-inducible factor 1 α protein expression is controlled by oxygen-regulated ubiquitination that is disrupted by deletions and missense mutations. *Proc. Natl. Acad. Sci. USA* **97**, 4748–4753.
- Tanimoto, K., Makino, Y., Pereira, T., and Poellinger, L. (2000). Mechanism of regulation of the hypoxia-inducible factor-1 α by the von Hippel-Lindau tumor suppressor protein. *EMBO J.* **19**, 4298–4309.
- Trent, C., Tsung, N., and Horvitz, H.R. (1983). Egg-laying defective mutants of the nematode *Caenorhabditis elegans*. *Genetics* **104**, 619–647.
- Wang, G.L., Jiang, B.-H., Rue, E.A., and Semenza, G.L. (1995). Hypoxia-inducible factor 1 is a basic-helix-loop-helix-PAS heterodimer regulated by cellular O₂ tension. *Proc. Natl. Acad. Sci. USA* **92**, 5510–5514.
- Wax, S.D., Rosenfield, C.L., and Taubman, M.B. (1994). Identification of a novel growth factor-responsive gene in vascular smooth muscle cells. *J. Biol. Chem.* **269**, 13041–13047.
- Wenger, R.H. (2000). Mammalian oxygen sensing, signalling and gene regulation. *J. Exp. Biol.* **203**, 1253–1263.
- Woodward, E.R., Hurst, L.D., Clifford, S.C., Affara, N.A., and Maher, E.R. (2000). Comparative sequence analysis of the *VHL* tumour suppressor gene. *Genomics* **65**, 253–265.
- Wu, M., Moon, H.S., Begley, T.P., Myllyharju, J., and Kivirikko, K.I. (1999). Mechanism-based inactivation of the human prolyl-4-hydroxylase by 5-oxaproline-containing peptides: evidence for a prolyl radical intermediate. *J. Am. Chem. Soc.* **121**, 587–588.
- Zhang, Z.H., Ren, J.S., Stammers, D.K., Baldwin, J.E., Harlos, K., and Schofield, C.J. (2000). Structural origins of the selectivity of the trifunctional oxygenase clavaminic acid synthase. *Nat. Struct. Biol.* **7**, 127–133.
- Zhou, J., Gunsior, M., Bachmann, B.O., Townsend, C.A., and Solomon, E.I. (1998). Substrate binding to the alpha-ketoglutarate-dependent non-heme iron enzyme clavaminic acid synthase 2: coupling mechanism of oxidative decarboxylation and hydroxylation. *J. Am. Chem. Soc.* **120**, 13539–13540.
- Zhu, H., and Bunn, H.F. (2001). How do cells sense oxygen? *Science* **292**, 449–451.